

► Code Number

3346096

► Description

The ESD-801 is part of Sloan's new line of matching combination soap dispensers and faucets. They are easy to order kits for any bathroom. The soap dispenser uses a replaceable soap refill bottle with easy release collar for fast soap refill changes. The sensor technology offers a hands-free operation by delivering a pre-measured foam soap application "on demand". The faucet is Sloan's EBF-85-4. The ESD-800 is also available for sale without faucet.

Contains:

- 1-EBF85-4 Chrome Faucet (3315010)
- 1-ESD-800 Soap Dispenser (3346097)
- 1-ESD-321 2 pack of 1500ml foam soap (3346044)

► Faucet

- Battery Powered, Sensor Activated Electronic Hand Washing Faucet for tempered or hot/cold water operation.
- Flow Rate: 0.5 gpm (1.9 Lpm)
- Fiber Optic, Automatic, Self-adaptive Sensing
- Isolated Latching Solenoid Operator, isolates magnetic components from water contact
- Audible Tone Low Battery Indicator
- Serviceable Filtered Solenoid Valve
- Vandal Resistant Spray Head with Pressure Compensating Flow Control
- Polypropylene Optic Cable Protection
- Bak-Chek® Tee for Hot/Cold Supply

► Faucet Electrical Specifications

- Maximum Distance Control Module may be Installed from Spout 30" (762 mm)
- Includes four (4) C-size Alkaline Batteries
- Battery Life 2 Years @ 8,000 Cycles / Month
- Sensor Range Nominal: 4" - 5" (102 mm - 127 mm) Self-adaptive Zone: 2" - 8" (51 mm - 203 mm) — Faucet selfadjustment range within this zone dependent upon depth and reflectivity of basin.
- 6 VDC — Operates on four (4) alkaline C-size batteries. Selfadaptive Range Adjustment, Audible Troubleshooting and Low Battery Indicator. Fiber Optic Cable between Electronic Module and Faucet keeps all electronic signals below the sink

► Soap Dispenser Electrical Specifications

- Ships with battery pack (4 "D" Alkaline batteries included)
- Optional AC adaptor can be purchased separately (part number 0346090)
- Sensor range – nominal 5"
- GFI outlet suggested per code
- 120V/15 Amp



► Soap Dispenser

- Modular one-piece construction is easy to install on a sink deck surface
- All electronics in spout are sealed
- Designed for drip free foam dispensing operation
- Motor Assembly suspended under counter connected to soap dispenser spout
- Motor Assembly rotates 360 degrees for easy installation
- Battery life of 45,000 activations
- 1,500 dispenses per foam soap bottle
- Ships with 2 bottles of non-scented, non-colored foam soap (1500ml per bottle)
- Additional foam soap can be purchased through Sloan (ESD-321) or GOJO distribution (8565-02-N6300GN)

► Compliance & Certifications

CEC Compliant



CALGreen

This space for Architect/Engineer Approval

EBF-85 Faucet with Bak-Chek® Tee for Hot and Cold Water Supply (shown with 4" trim plate)

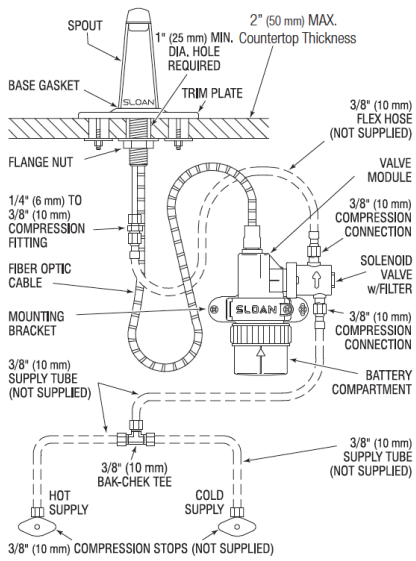

EBF-85 Faucet with ADM Variation Mixing Valve for Hot and Cold Water Supply (shown with 8" trim plate)

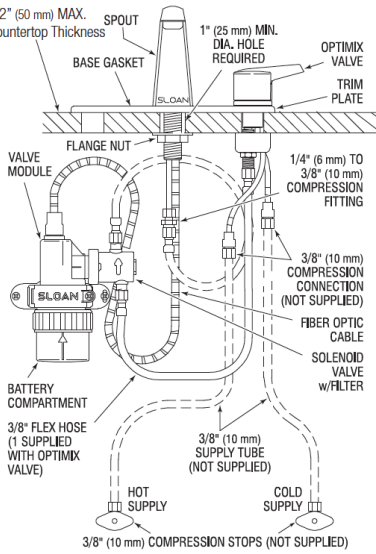

EBF-85 Faucet with BDM and BDT Variation Mixing Valves for Hot and Cold Water Supply (shown with 4" trim plate)

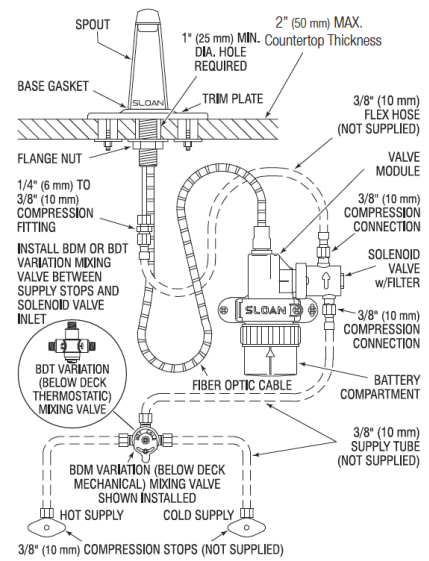

EBF-85-4 Faucet

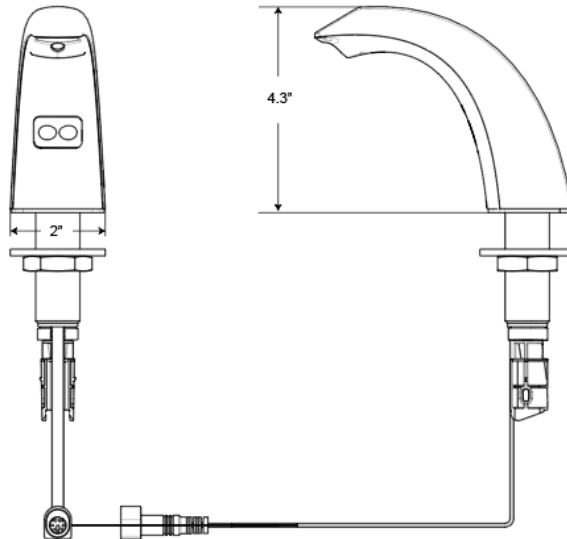
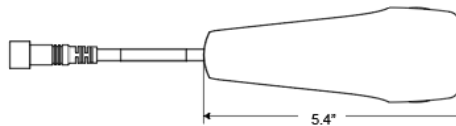

ESD-800 Soap Dispenser