

► **Code Number**

3346094

► **Description**

The ESD-701 is part of Sloan's new line of matching combination soap dispensers and faucets. They are easy to order kits for any bathroom. The soap dispenser uses a replaceable soap refill bottle with easy release collar for fast soap refill changes. The sensor technology offers a hands-free operation by delivering a pre-measured foam soap application "on demand". The faucet is Sloan's EAF-750-ISM. The ESD-700 is also available for sale without faucet.

► **Notes**

Contains:

- 1- EAF750-ISM Chrome Faucet (3335074)
- 1- EAF-700 Soap Dispenser (3346095)
- 1-ESD-321 2 pack of 1500ml foam soap (3346044)

► **Faucet**

- Sensor Activated, Electronic, Chrome Plated Die-Cast Metal, Gooseneck Hand Washing Faucet with the following features:
- Flow Rate: 1.5 gpm / 5.7 Lpm
- Temporary-off Feature for Cleaning
- 12/24 hour Hygienic Rinse Line Purge Function – Field Settable
- Unitary Spout Housing Assembly for Easy Cleaning
- Modular One-piece Construction with all Concealed Components above deck
- Double Infrared Sensors with Automatic Setting Feature and Microprocessor
- Low Battery Indicator
- Bi-stable Magnetic Solenoid Valve

► **Faucet Electrical Specifications**

- 6 volt Lithium CR-P2 Commercial Battery included
- 6.75 VDC — Includes Auto Set Range Adjustment and Low Battery Indicator LED
- 6 VDC Lithium CR P2 battery Up to Ten (10) Year Battery Life
- Faucet Adaptive Self-adjustment Range: 2"-14" (51 mm -356 mm) nominal Nominal: 4" - 5" (102 mm - 127 mm)

► **Soap Dispenser Electrical Specifications**

- Ships with battery pack (4 "D" Alkaline batteries included)
- Optional AC adaptor can be purchased separately (part number 0346090)
- Sensor range – nominal 5"
- GFI outlet suggested per code
- 120V/15 Amp



► **Soap Dispenser**

- Modular one-piece construction is easy to install on a sink deck surface
- All electronics in spout are sealed
- Designed for drip free foam dispensing operation
- Motor Assembly suspended under counter connected to soap dispenser spout
- Motor Assembly rotates 360 degrees for easy installation
- Battery life of 45,000 activations
- 1,500 dispenses per foam soap bottle
- Ships with 2 bottles of non-scented, non-colored foam soap (1500ml per bottle)
- Additional foam soap can be purchased through Sloan (ESD-321) or GOJO distribution (8565-02-N6300GN)

► **Compliance & Certifications**



This space for Architect/Engineer Approval

**EAF-750**  
Faucets with Single Line Water Supply

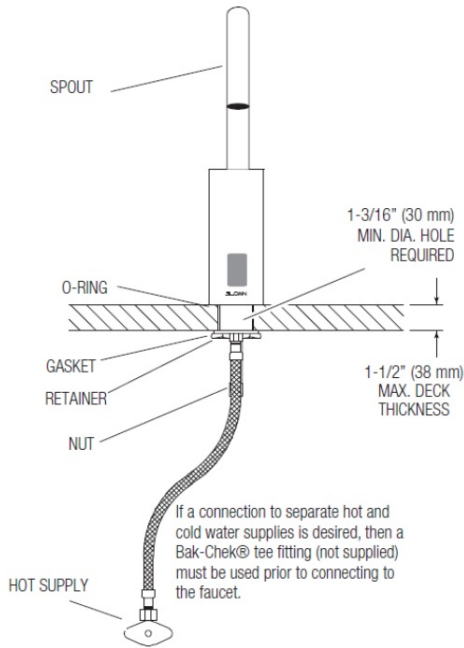

**EAF-750-ISM**  
Faucets with Hot and Cold Water Supply

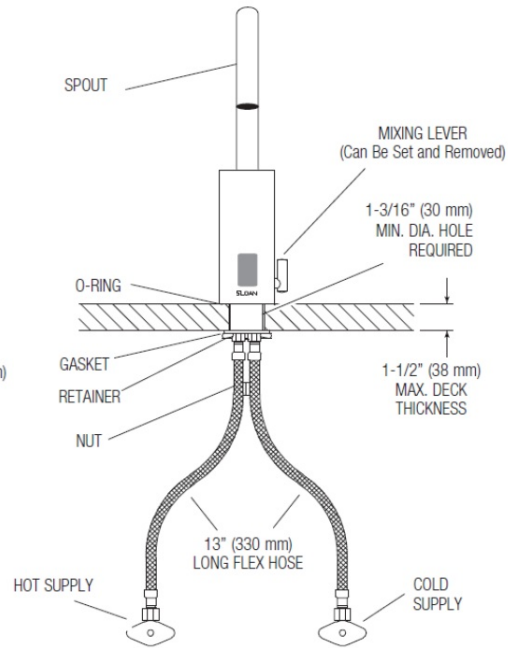

EAF-750-ISM Faucet

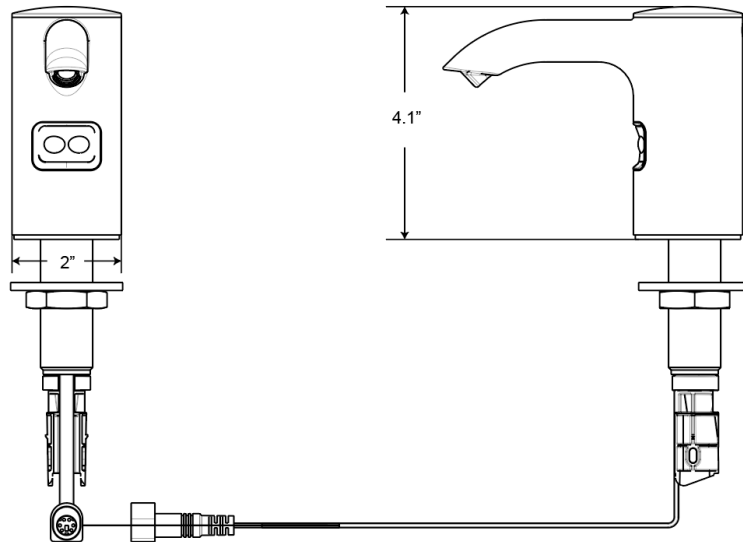
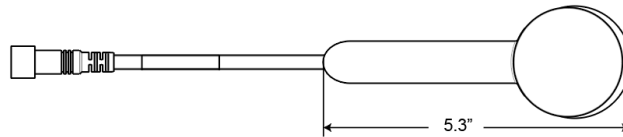

ESD-700 Soap Dispenser