

INSTALLATION INSTRUCTIONS FOR BATTERY POWERED SENSOR ACTIVATED LAVATORY FAUCETS

EBF-615
Pedestal,
Battery Powered,
Sensor Activated
Lavatory Faucet



EBF-650
4" Centerset,
Battery Powered,
Sensor Activated
Lavatory Faucet



LIMITED WARRANTY

Sloan Valve Company warrants its EBF-615 and EBF-650 Faucets to be made of first class materials, free from defects of material or workmanship under normal use and to perform the service for which they are intended in a thoroughly reliable and efficient manner when properly installed and serviced, for a period of three years (1 year for special finishes) from date of purchase. During this period, Sloan Valve Company will, at its option, repair or replace any part or parts which prove to be thus defective if returned to Sloan Valve Company, at customer's cost, and this shall be the sole remedy available under this warranty. No claims will be allowed for labor, transportation or other incidental costs. This warranty extends only to persons or organizations who purchase Sloan Valve Company's products directly from Sloan Valve Company for purpose of resale. This warranty does not cover the life of the batteries.

THERE ARE NO WARRANTIES WHICH EXTEND BEYOND THE DESCRIPTION ON THE FACE HEREOF. IN NO EVENT IS SLOAN VALVE COMPANY RESPONSIBLE FOR ANY CONSEQUENTIAL DAMAGES OF ANY MEASURE WHATSOEVER.

PRIOR TO INSTALLATION

Prior to installing the Sloan EBF-615 or EBF-650 faucet, install the items listed below. Also, refer to rough-in illustrations on Page 2.

- Lavatory/sink
- Drain line
- Hot and cold water supply lines or tempered water supply line

Mixing Valve

When installing the faucet with a Sloan Mixing Valve, these Installation Instructions AND the Installation Instructions packaged with the Mixing Valve MUST be followed.

Important:

- **ALL PLUMBING IS TO BE INSTALLED IN ACCORDANCE WITH APPLICABLE CODES AND REGULATIONS.**
- **KEEP THREAD SEALANT OUT OF YOUR WATERWAY TO PREVENT COMPONENT PART DAMAGE! DO NOT USE ANY SEALANT ON COMPRESSION FITTINGS. FOR THREADED PIPE FITTINGS, DO NOT APPLY SEALANT TO THE FIRST TWO "STARTER" THREADS.**
- **FLUSH ALL WATER LINES UNTIL WATER IS CLEAR BEFORE CONNECTING SOLENOID TO SUPPLY STOPS.**

DO NOT INSTALL THE BATTERIES UNTIL THE FAUCET IS COMPLETELY INSTALLED. If batteries are installed before sensor cable is connected to control module, the faucet will not properly set the sensing range for the sink on which it is installed.

TOOLS REQUIRED FOR INSTALLATION

- Open end wrenches for the following hex sizes: 1/2", 9/16", 5/8", 11/16", 1"
- Basin wrench
- Phillips head screwdriver, #2
- Hammer (if installing plastic or hollow wall anchors to mount the control module)
- Pliers
- 1/4" drill bit (if installing plastic wall anchors to mount the control module)
- 5/16" drill bit (if installing hollow wall anchors to mount the control module)
- 3/8" drill bit (if installing toggle nut anchors to mount control module)

Bak-Chek® Tee Usage

When connecting the EBF-615 or EBF-650 faucet to both hot and cold water supplies, a Bak-Chek® Tee is provided and required as illustrated in Step 3. Water temperature can be controlled by adjusting the supply stops. When connecting the faucet to a single line water supply or a pre-tempered water supply, a Bak-Chek® Tee is not required. A Bak-Chek® Tee is not required or provided when a Temperature Mixing Valve is included with the faucet.



FAUCET ROUGH-IN

EBF-615 Faucet with Bak-Chek® Tee for Hot and Cold Water Supply (shown with 4" trim plate)

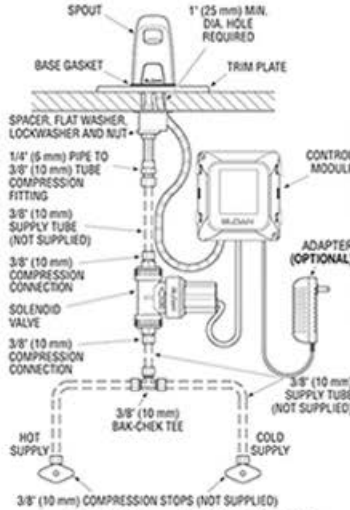

EBF-615 Faucet with ADM Variation Mixing Valve for Hot and Cold Water Supply (shown with 8" trim Plate)

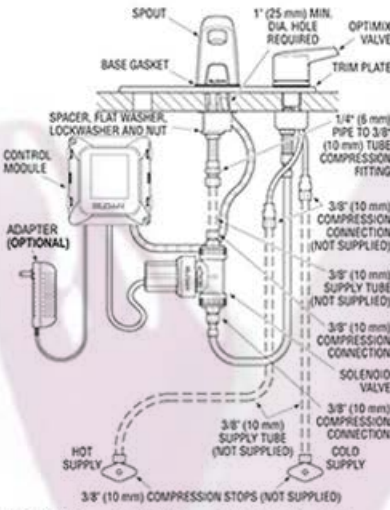

EBF-615 Faucet with BDM and BDT Variation Mixing Valves for Hot and Cold Water Supply (shown with 4" trim Plate)

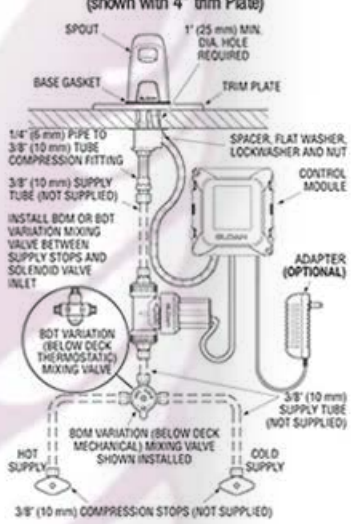

EBF-650 Faucet with Bak-Chek® Tee for Hot and Cold Water Supply

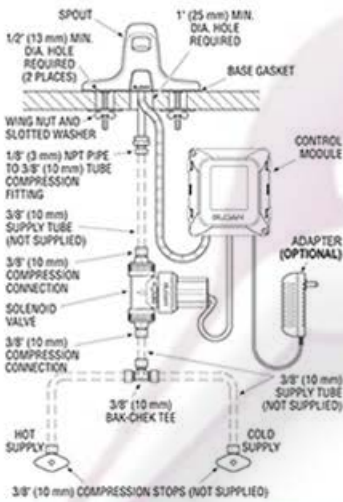

EBF-650 Faucet with BDM and BDT Variation Mixing Valves for Hot and Cold Water Supply

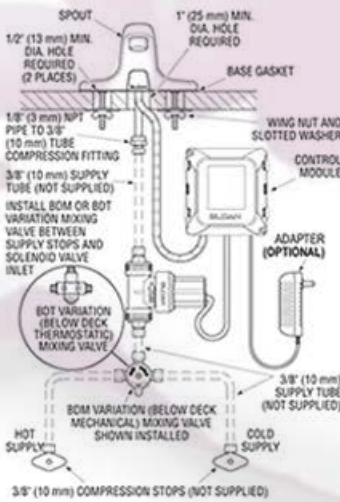

FAUCET SIDE VIEW

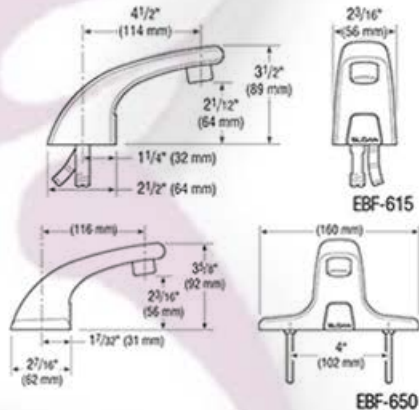

1A - Install Faucet Spout and Optional Trim Plate — EBF-615

Sloan Valve Company recommends installation of our trim plate with anti-rotation feature to prevent rotation of this single-hole pedestal-style faucet.

A Install Faucet Spout as shown. Use plumber's putty to secure optional Trim Plate, if used.

Important: After installing Mounting Nut, apply thread sealant or Teflon tape to threads of Water Supply Tube.

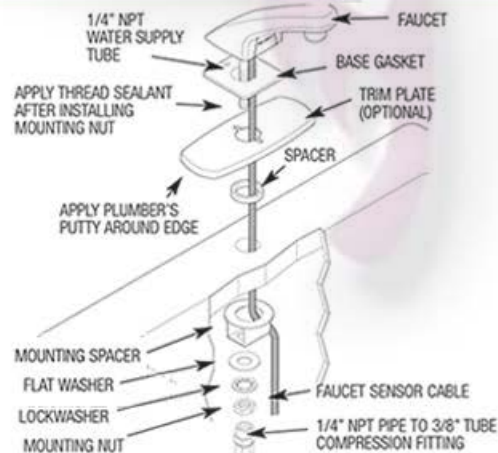

1B - Install Faucet Spout – EBF-650

Refer to the Installation Instructions included with the ETF-578-A Trim Plate for additional information about using an 8" Trim Plate with an EBF-650 faucet.

- A** Install Faucet Spout as shown.
Important: Apply thread sealant or Teflon tape to threads of Water Supply Pipe Nipple.

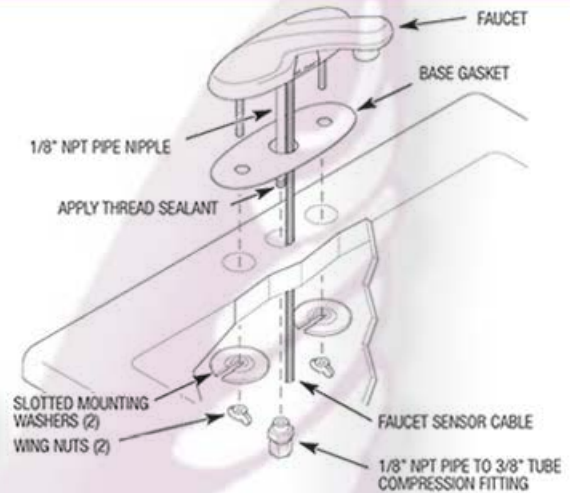

2 - Install Solenoid Valve

Flow direction of Solenoid Valve is indicated by an arrow on Valve Body.

- A** Install 3/8 inch (10 mm) supply tube (furnished by installer) between the Compression Fittings on Spout and the top outlet of Solenoid Valve.

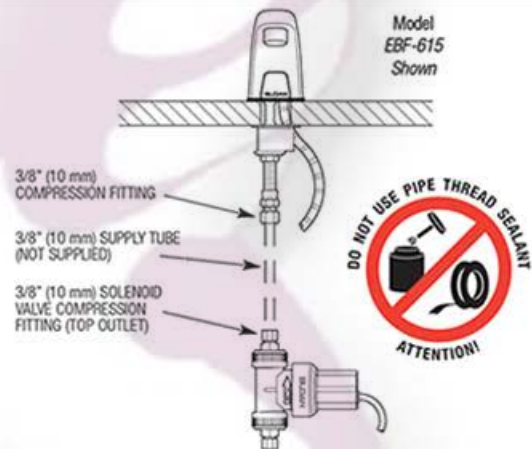

3 - Connect Supply Line(s) from Supply Stop(s) to Solenoid Valve Inlet

Important: Keep thread sealant out of your waterway and prevent component part damage! Do not use sealant on compression fittings. When thread sealant is used, do not apply it to the first two "starter" threads.
Important: Flush dirt, debris, and sediment from the supply line(s).

- A** Dual Line Hot and Cold Water Supply Applications
Install a 3/8 inch (10 mm) copper supply tube between Bak-Chek® Compression Tee and hot and cold supply stops. (Supply tubes and stops furnished by installer.) Install a 3/8 inch (10 mm) copper supply tube between Bak-Chek Compression Tee and inlet side of Solenoid Valve. Tighten Compression Fittings securely.

Note: Failure to install the Bak-Chek® Tee can result in a cross flow connection when the faucet is off and the supply stops are open. If pressure of the hot and cold water supply differ, hot water can migrate into the cold water supply or vice-versa. Most plumbing codes require that the Bak-Chek® be used to prevent this.

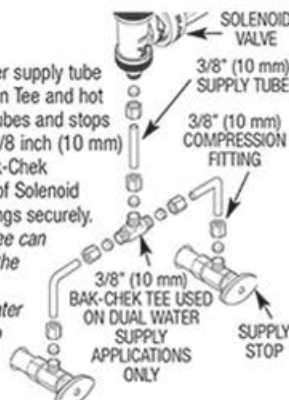

- B** Single Line Water Supply Applications

Install a 3/8 inch (10 mm) copper supply tube between the supply stop and inlet side of the Solenoid Valve. (Supply tube and supply stop furnished by installer.) Tighten Compression Fittings securely.

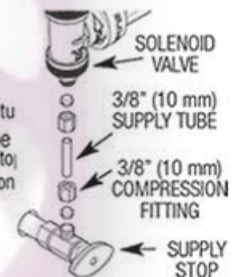

4 - Mount Control Module to Wall

- A** Install the Control Module in an appropriate location. Control Module must be installed so that all cables enter from the bottom of the unit. When installed, Cables from the Spout and Solenoid Valve to the Control Module should have some slack.
- B** Mount Control Module to wall using Mounting Screws and Plastic Anchors.

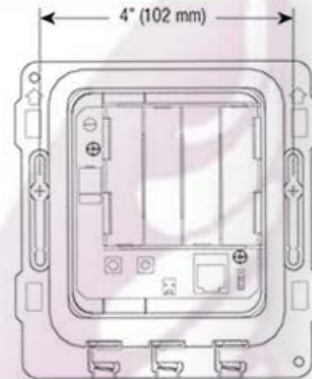

5 - Control Module Connection

- A** Route Cables from Solenoid Valve and Spout to the Control Module.
- B** Insert Locking Connector from Solenoid Valve into mating Receptacle.
- C** Insert Connector from Faucet Spout into Modular Receptacle.
- D** Insert Power Cable Jack from Adapter (optional) into Receptacle.
- E** Insert each Cable into a Strain Relief Slot.

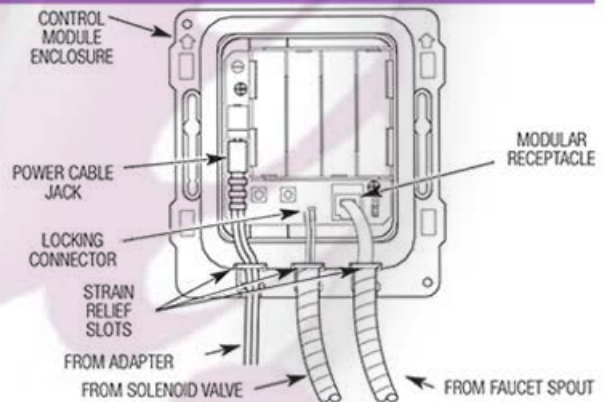

6 - Install Batteries

- A** Insert four (4) AA-size Alkaline Batteries provided as indicated by the (+) and (-) symbols inside the Battery Compartment.

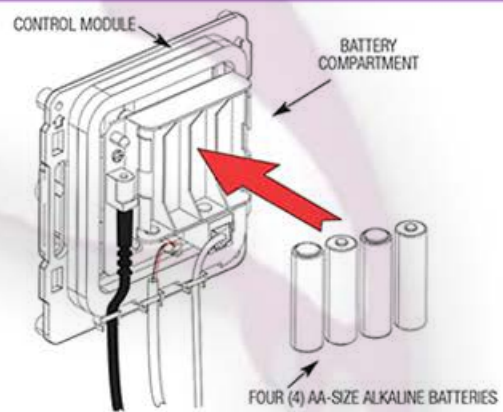

7 - Plug in Adapter (Optional)

- A** Plug Adapter into Receptacle.

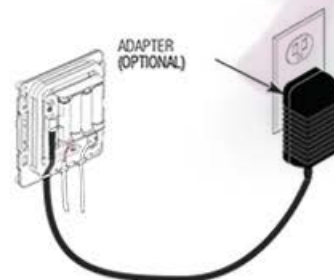

8 - Start-Up

- A** Activate ("dry fire") Faucet by placing hands in front of the Sensor. The Solenoid Valve should "click." Once hands are removed the Solenoid Valve should click again. If this does not occur, refer to the Troubleshooting section of this instruction manual.

Once "dry firing" segment is complete, remove spray head. Open supply stop(s) then activate Faucet by placing hands in front of the Sensor. The Solenoid Valve should "click" and water should flow from the Spout.

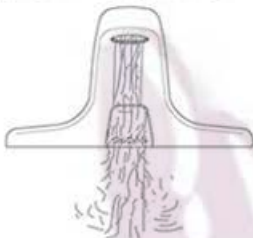

- B** Activate Faucet for 30 seconds by placing hands in front of the Sensor. The Solenoid Valve should "click" and water should flow from the Spout. If this does not occur, refer to the Troubleshooting section of this instruction manual.

- C** Close supply stop(s) and reinstall Spray Head in Spout using the Key provided. Reopen supply stop(s), activate Faucet and check for leaks.

9 - Range Adjustment

The OPTIMA Plus EBF-615 and EBF-650 Faucets are factory set to operate when hands are placed 4 to 5 inches (102 to 127 mm) from Sensor. This range should be satisfactory for most installations. If range adjustment is required, refer to the following range adjustment procedure.

- A** The Range Potentiometer is located in the Control Module.

Important: Range Potentiometer adjustment screw rotates only 3/4 of a turn; DO NOT over-rotate. Over-rotating will damage range adjustment screw.

- B** Cycle Faucet several times to assure that the Sensor will not inadvertently pick up reflection off the edge of the sink. If reflection occurs, adjust Range Potentiometer counterclockwise very slightly and again cycle Faucet.

Repeat adjustment procedure until desired range is achieved.

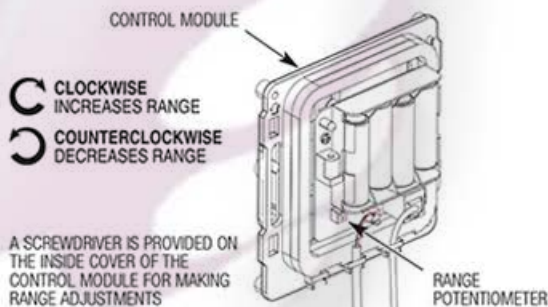

10 - Noise Reduction (NR) and Time Out (Mode) Jumper Settings

For jumper settings, refer to Table below or label on cover of Control Module along with the instructions in this Step.

Noise Reduction (NR) Setting

- When operating the faucet on batteries alone, set the NR jumper to bridge pins 1 and 2.
- When operating the faucet using the plug-in adapter with battery backup, bridge pins 2 and 3.

Time Out (Mode) Setting

The Faucet Time Out Setting determines the maximum time the Faucet will run upon continuous activation. This timing can be changed to meet individual application requirements.

Unless otherwise specified, Faucets leave the factory set with a 30 second Time Out.

DESCRIPTION	PINS		
	1	2	3
NOISE REDUCTION (NR) SETTING			
Normal Operation (Adapter w/Battery Backup Operation)	●	●	
NR Enabled (Battery Operation Only)		●	●
TIME OUT (MODE) SETTING			
13.75 Second On Demand	●	●	
30 Second On Demand		●	●

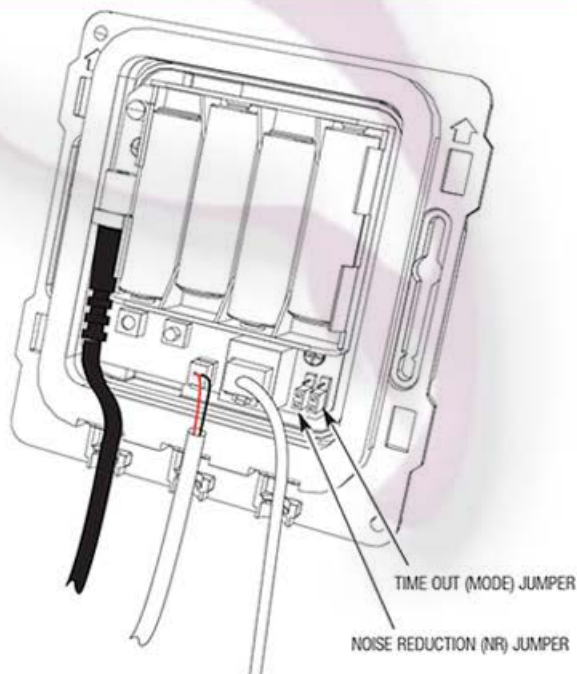

11 - Install Cover onto Control Module

- A** Install Cover over the Control Module making sure that all four (4) locking tabs snap into place. Secure using the two (2) screws provided. Cover can be installed in only one orientation.

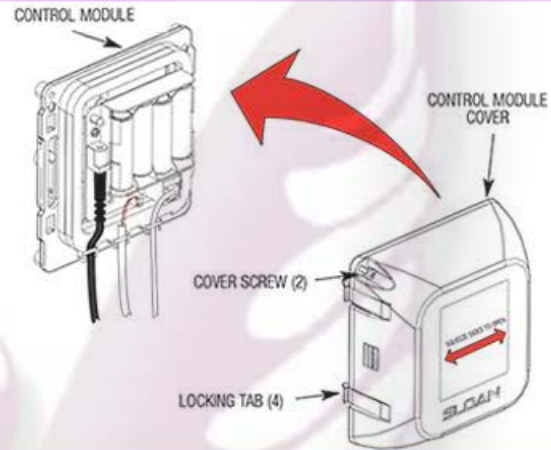

Operation

1. A continuous invisible beam of infrared light is emitted from the sensor located on the throat of the lavatory faucet.



2. As the user's hands enter the beam's effective range (beneath the spray head), the beam is reflected back into the sensor receiver and activates the solenoid valve. Tempered water flows from the faucet into the sink until the hands are removed from the beam or until the faucet reaches an automatic time out limit setting.



3. When hands are moved away from the sensor, the loss of reflected light initiates an electrical signal that deactivates the solenoid valve, shutting off the water flow. The circuit then automatically resets and is ready for the next user.



Care and Cleaning

DO NOT USE abrasive or chemical cleaners (including chlorine bleach) to clean faucets as they may dull the luster and attack the chrome or special decorative finishes. Use **ONLY** soap and water, then wipe dry with clean cloth or towel.

While cleaning the bathroom tile, the faucet should be protected from any splattering of cleaner. Acids and cleaning fluids will discolor or remove chrome plating.



Battery Replacement Procedure (Water does not need to be turned off)

The Sloan Optima Plus EBF-615 and EBF-650 faucets are furnished with four (4) AA-size alkaline batteries that provide up to two (2) years of operation (8000 cycles per month). A flashing LED signal indicates that battery power will be depleted within one (1) month.

- A** Remove Cover as follows:
1. Remove the two (2) Cover Screws.
 2. Press in the middle of both sides.
 3. Pull Cover straight out from Control Module Base.

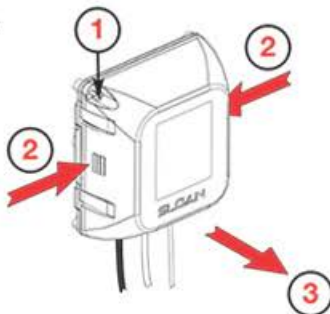

- B** Remove old batteries and insert four (4) new AA-size Alkaline Batteries as indicated by the (+) and (-) symbols inside the Battery Compartment.

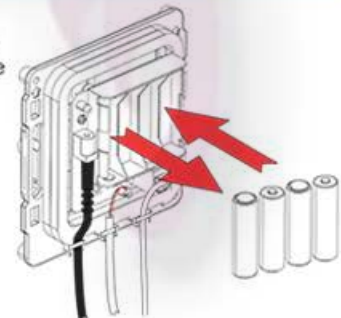

- C** Reinstall Cover. Refer to Step 11.



Solenoid Screen Filter Cleaning Procedure

- A** Turn off water supply at supply stop(s). Activate Faucet to relieve system pressure.
- B** Remove Water Supply Line from Inlet Side of Solenoid Valve. Remove Cap, Water Line Fitting, Gasket, Filter Housing and Filter from Solenoid Valve Housing.
- C** Slide Filter off Filter Housing. Clean Filter using fresh tap water only. If necessary, use a small brush to clean. Use caution while cleaning to prevent damage to Filter.
If any Filter components are damaged, replace as necessary. Examine the Gasket for wear or damage; replace if necessary.
- D** Reinstall Filter on Filter Housing.
Install Filter Housing, Gasket, Water Line Fitting and Cap onto Solenoid Valve Housing.
Tighten Cap securely.

- E** Reinstall Water supply Line to Inlet Side of Solenoid Valve.

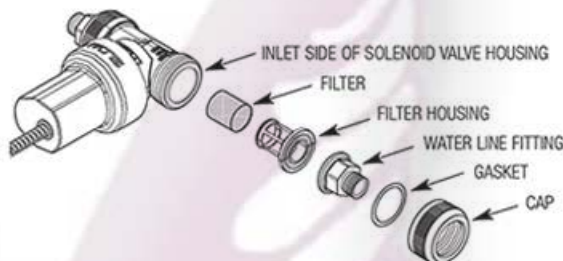

Troubleshooting Guide

- 1. PROBLEM:** Sensor LED does not function (indicator light on sensor window in faucet spout does not flash during initial 10 minute set-up mode).

CAUSE: There is no visible indicator light. Normal operation.

SOLUTION: This is a normal operating feature of the faucet.
- 2. PROBLEM:** Faucet does not deliver any water when Sensor is activated.

INDICATOR: Solenoid valve produces audible "CLICK."

CAUSE: Water supply stop(s) closed.

SOLUTION: Open supply stop(s) completely.

INDICATOR: Solenoid valve DOES NOT produce an audible "CLICK."

CAUSE: Solenoid Lead is not properly connected to the Control Module.

SOLUTION: Disconnect and reconnect Solenoid Lead to the Control Module.

CAUSE: No battery or Transformer (optional) power is being supplied to Sensor.

SOLUTION: Ensure that the batteries are installed properly. Check that the orientation of each battery matches the positive (+) and negative (−) symbols shown on the bottom of the battery compartment. Reinsert the Batteries into the Control Module. Transformer (optional) is unplugged or wall receptacle has no power.

CAUSE: Sensor Cable is not properly connected to the Control Module.

SOLUTION: Disconnect and reconnect Sensor Cable to the Control Module.

CAUSE: Sensor range is set at minimum distance.

SOLUTION: Increase Sensor range. Refer to Step 9, Range Adjustment.

CAUSE: Control Module assembly is defective.

SOLUTION: Replace Control Module assembly.
- 3. PROBLEM:** Faucet delivers only a slow flow or dribble when Sensor is activated.

CAUSE: Water supply stop(s) partially closed.

SOLUTION: Open supply stop(s) completely.

CAUSE: Solenoid Filter is clogged.

SOLUTION: Remove, clean and reinstall Filter. Refer to Solenoid Screen Filter Cleaning Procedure on Page 6. Replace with new Solenoid Filter Kit if necessary.

CAUSE: Aerator is clogged.

SOLUTION: Remove, clean and reinstall Aerator.
- 4. PROBLEM:** Faucet does not stop delivering water or continues to drip after user is no longer detected (automatic shut-off fails even when batteries are removed).

CAUSE: Solenoid Valve has been connected backwards.

SOLUTION: Disconnect Solenoid Valve compression fittings at both the inlet and outlet positions. The water should flow from inlet through the Solenoid Valve to the outlet according to the direction of the arrow shown on the side of the Solenoid Valve. Reconnect the compression fittings in the correct orientation.

CAUSE: Solenoid Valve is dirty.

SOLUTION: Backflush by reversing water flow (opposite to the direction shown by the arrow on the side of the Solenoid Valve) through the Solenoid Valve. Reconnect the compression fittings in the correct orientation. Activate faucet.

CAUSE: Solenoid Valve Module is defective.

SOLUTION: Replace Solenoid Valve Module.
- 5. PROBLEM:** The water temperature is too hot or too cold on a faucet connected to hot and cold supply lines with Bak-Chek Tee.

CAUSE: Supply stops are not adjusted properly.

SOLUTION: Adjust supply stops.

NOTE: For some systems, a Thermostatic Mixing Valve may be required.
- 6. PROBLEM:** The Red LED turns on in the control module (below deck).

CAUSE: One (or more) of the batteries is "dead."

SOLUTION: To ensure proper operation, insert four (4) new AA-size Alkaline batteries. Check that the orientation of each battery matches the positive (+) and negative (−) symbols shown on the bottom of the battery compartment. Reinsert Batteries into the Control Module.

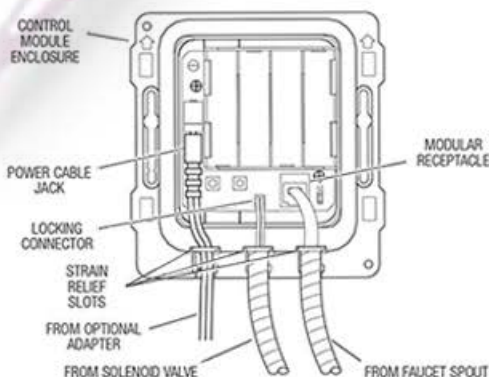

PARTS LIST

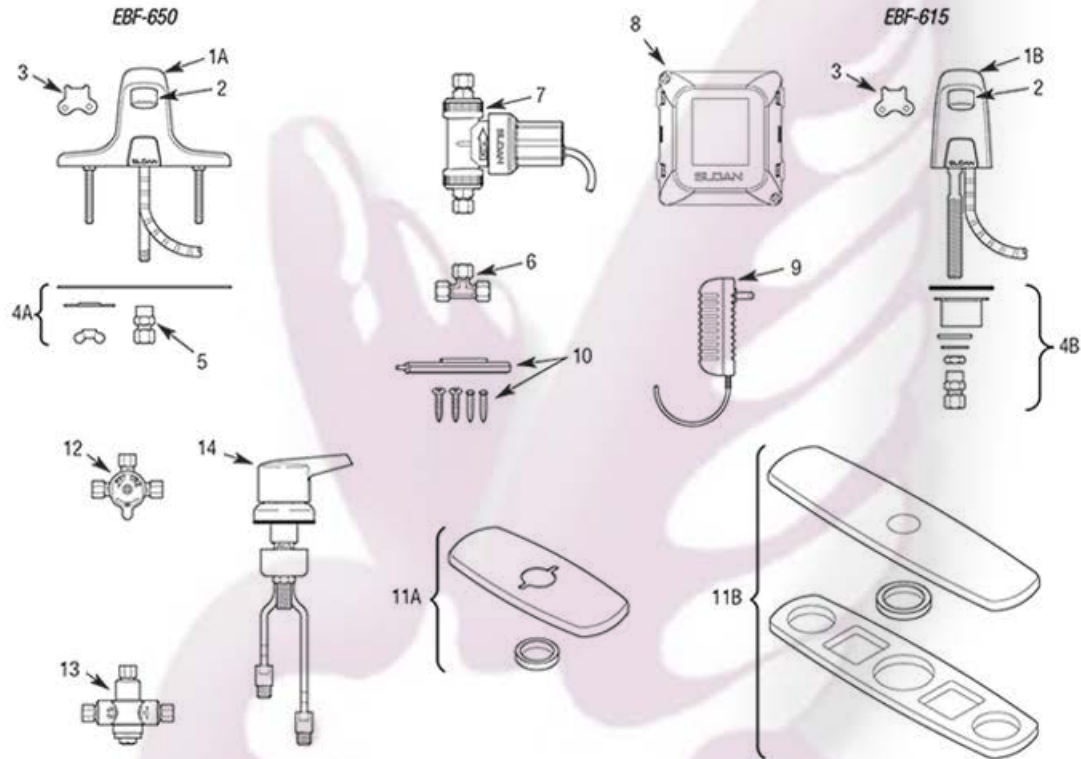

Item No.	Part No.	Description
1A	ETF-755-A	CP Faucet Assembly 4" Centerset (ETF-650)
1B	EBF-120-A	Pedestal Faucet Spout and Sensor Assembly (EBF-615)
—	ETF-749-A	Sensor Only
2	ETF-1023-A	0.5 gpm (1.9 Lpm) Spray Head with Key (male thread)
	ETF-1024-A	2.2 gpm (8.3 Lpm) Aerator Spray Head with Key (male thread)
	F-174	CP Spray Head 0.5 gpm Laminar Flow Spray Head (male thread)
3	ETF-435	Replacement Key Only for ETF-1023-A 0.5 gpm (1.9 Lpm) Spray Head and ETF-1024-A 2.2 gpm (8.3 Lpm) Aerator Spray Head (NOT required for F-175-L 2.2 gpm/8.3 Lpm Laminar Flow Spray Head)
4A	ETF-546-A	Faucet Mounting Kit for EBF-650 includes Base Gasket, two (2) Slotted Mounting Washers, two (2) Wing Nuts and ETF-547 Compression Fitting Connector
4B	EBF-123-A	Faucet Mounting Kit for EBF-615 includes Base Gasket, Spacer, Washer, 9/16" Lockwasher, 1/4" NPSM Hex Nut and ETF-547 Compression Fitting Connector
5	ETF-547	1/8" NPT Pipe to 3/8" Tube Compression Fitting Connector (female)
6	ETF-617-A	3/8" Bak-Chek® Tee Compression Fitting
7	ETF-740-A	6 VDC Solenoid Assembly
8	ETF-735-A	Control Module
—	ETF-736	Control Module Replacement Gasket (two required)

Item No.	Part No.	Description
9	SFP-6	110 VAC/6 VDC Plug-in Adapter (optional)
10	ETF-443-A	Hardwired Mounting Kit (optional)
—	EBF-113	Compression Fitting Kit (optional) includes:
	ETF-209	2 compression nuts
	ETF-208	2 ferrules
	ETF-91	1 plastic screwdriver

OPTIONAL TRIM PLATES

11A	ETF-607-A	4" (102 mm) Centerset Single-hole Trim Plate Kit for EBF-615 Faucet (Faucet only)
11B	ETF-608-A	8" (204 mm) Centerset Single-hole Trim Plate Kit for EBF-615 Faucet (Faucet only)

OPTIONAL MIXING VALVES

12	MIX-60-A	Below Deck Mechanical Water Mixing Valve (BDM Variation)
13	MIX-135-A	Below Deck Thermostatic Water Mixing Valve (BDT Variation)
14	MIX-110-AA	Optimix® Deck Mounted Water Mixing Valve (only available for EBF-615 faucets)

