

**OPTIMA**  
*plus*

## INSTALLATION INSTRUCTIONS FOR BATTERY POWERED SENSOR ACTIVATED HAND WASHING FAUCETS



**Model EBF-550-S-H**  
Wall Mounted, Battery Powered, Sensor Activated,  
Gooseneck Hand Washing Faucet  
With Surgical Bend Spout and Shower Spray Head

**Model EBF-750**  
Deck Mounted, Battery Powered, Sensor  
Activated, Gooseneck Hand Washing Faucet  
With Standard Spout and Laminar Flow Spray Head



### LIMITED WARRANTY

Sloan Valve Company warrants its EBF-550 and EBF-750 Faucets to be made of first class materials, free from defects of material or workmanship under normal use and to perform the service for which they are intended in a thoroughly reliable and efficient manner when properly installed and serviced, for a period of three years (1 year for special finishes) from date of purchase. During this period, Sloan Valve Company will, at its option, repair or replace any part or parts which prove to be thus defective if returned to Sloan Valve Company, at customer's cost, and this shall be the sole remedy available under this warranty. No claims will be allowed for labor, transportation or other incidental costs. This warranty extends only to persons or organizations who purchase Sloan Valve Company's products directly from Sloan Valve Company for purpose of resale. This warranty does not cover the life of the batteries.

THERE ARE NO WARRANTIES WHICH EXTEND BEYOND THE DESCRIPTION ON THE FACE HEREOF. IN NO EVENT IS SLOAN VALVE COMPANY RESPONSIBLE FOR ANY CONSEQUENTIAL DAMAGES OF ANY MEASURE WHATSOEVER.

### PRIOR TO INSTALLATION

Prior to installing the Sloan EBF-550 or EBF-750 Faucet, install the items listed below. Also, refer to the Rough-In illustrations on Page 2.

- Scrub or wash-up sink
- Drain line
- Hot and cold water supply lines or tempered water supply line

#### Mixing Valve

When installing the faucet with a Sloan mixing valve, these Installation Instructions AND the Installation Instructions packaged with the mixing valve MUST be followed.

#### Important:

- **INSTALL ALL PLUMBING IN ACCORDANCE WITH APPLICABLE CODES AND REGULATIONS.**
- **KEEP THREAD SEALANT OUT OF YOUR WATERWAY TO PREVENT COMPONENT PART DAMAGE! DO NOT USE ANY SEALANT ON COMPRESSION FITTINGS. FOR THREADED PIPE FITTINGS, DO NOT APPLY SEALANT TO THE FIRST TWO "STARTER" THREADS.**
- **FLUSH ALL WATER LINES UNTIL WATER IS CLEAR BEFORE CONNECTING SOLENOID TO SUPPLY STOPS.**
- **DO NOT INSTALL THE SPRAY HEAD UNTIL AFTER THE SUPPLY LINES HAVE BEEN FLUSHED.**

- **DO NOT INSTALL THE BATTERIES UNTIL THE FAUCET IS COMPLETELY INSTALLED. If the batteries are installed before the sensor cable has been connected to the control module, the faucet will not properly set the sensing range for the sink on which it is installed.**

#### FLOW RATE

The EBF-550-H and EBF-750-H Faucets with shower spray head incorporate a 2.2 gpm (8.3 Lpm) maximum flow control. If water flow is too forceful, reduce flow to Faucet by adjusting supply stops. If a pressure reducing valve has been installed, adjust valve until optimum spray is obtained. Best performance is achieved between 25 and 40 psi.

#### BAK-CHEK® TEE USAGE

When connecting the Sloan EBF-550 or EBF-750 Faucet to both hot and cold water supplies, a Bak-Chek® Tee is provided and required as shown in the Rough-In illustrations on Page 2. Water temperature can be controlled by adjusting the supply stops.

When connecting the faucet to a single line water supply or a pre-tempered water supply, a Bak-Chek® Tee is not required.

A Bak-Chek® Tee is not required or provided when a Temperature Mixing Valve is included with the faucet.

### TOOLS REQUIRED FOR INSTALLATION

- Open end wrenches for hex sizes: 1/2", 9/16", 5/8", 11/16", 15/16" 1" and 1-3/16".
- Basin wrench and pipe wrench
- Slotted screwdriver, 1/4"; Phillips head screwdriver, #2 and #3
- Hammer (if installing wall anchors to mount control module)
- Drill (if installing wall anchors to mount control module or installing optional EBF-550 spout anti-rotation feature)
- 1/4" drill bit (if plastic wall anchors are used to mount control module)
- 7/64" drill bit (if installing optional EBF-550 spout anti-rotation feature)



**FAUCET ROUGH-IN**

**EBF-550 Faucet with Bak-Chek® Tee or BDM and BDT Variation Mixing Valves for Hot and Cold Water Supply or Single Line Water Supply †**

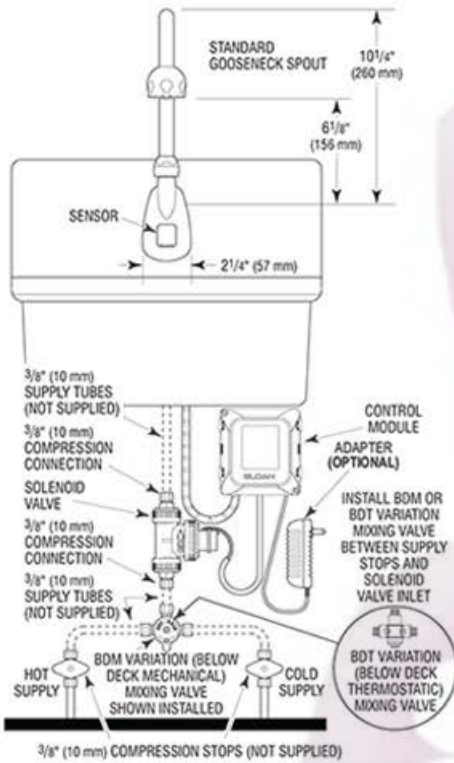

**EBF-550-H with Standard Spout and Shower Spray Head †**

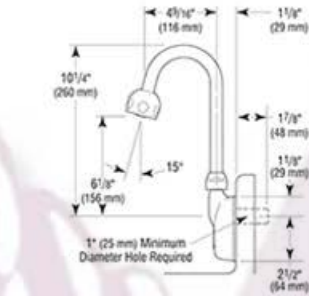

**EBF-750-H with Standard Spout and Shower Spray Head †**

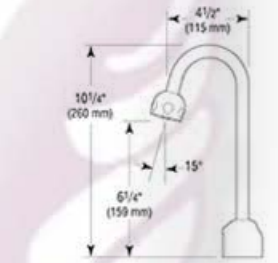

**EBF-550-S-H with Surgical Bend Spout and Shower Spray Head †**

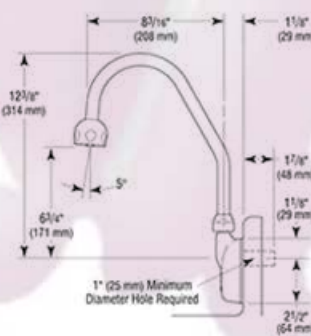

**EBF-750-S-H with Surgical Bend Spout and Shower Spray Head †**

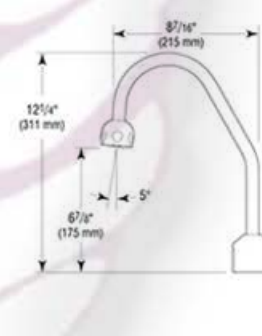

† The wide Spray Head is recommended for use on scrub or deep wash-up sinks only. For lavatories and small basins, use the Laminar Flow Spray Head.

**EBF-750 Faucet with Bak-Chek® Tee for Hot and Cold Water Supply †**

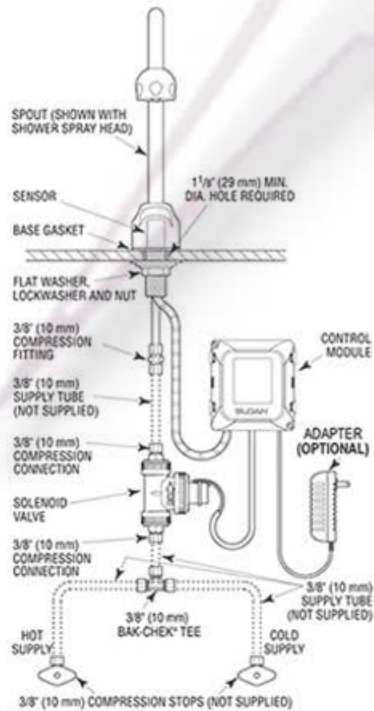

**EBF-750 Faucet with ADM Variation Mixing Valve for Hot and Cold Water Supply † (shown with 8" trim plate)**

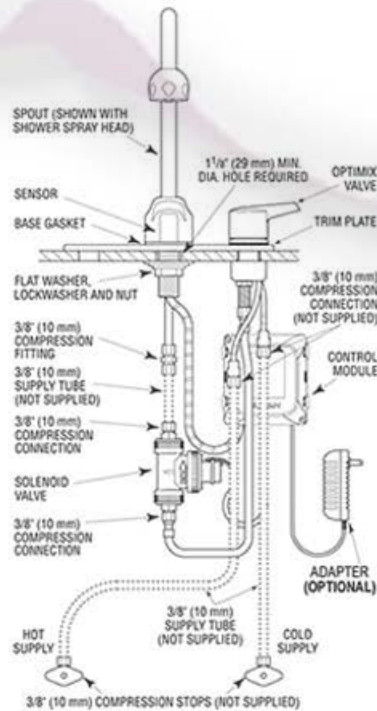

**EBF-750 Faucet with BDM and BDT Variation Mixing Valves for Hot and Cold Water Supply †**

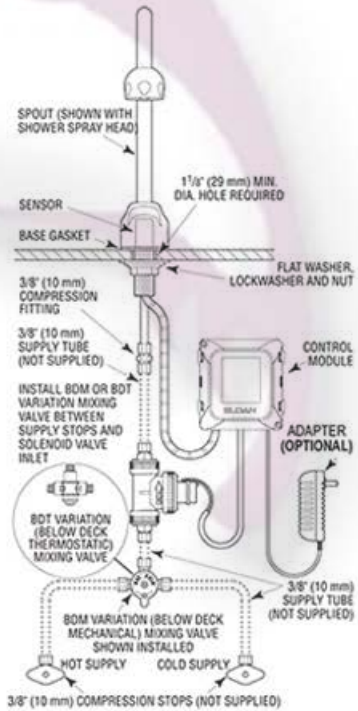

## 1A - INSTALL FAUCET SPOUT - EBF-750

**Note:** When installing with a Sloan Mixing Valve, install Faucet and Trim Plate before installing Mixing Valve. For complete installation guidelines, refer to the Installation Instructions supplied with the Sloan mixing valve.

- A** Insert Sensor Cable and Spout Shank through Base Gasket, optional Trim Plate with Spacer, and center deck hole.
- B** Secure using the Flat Washer, Lockwasher and Nut supplied.

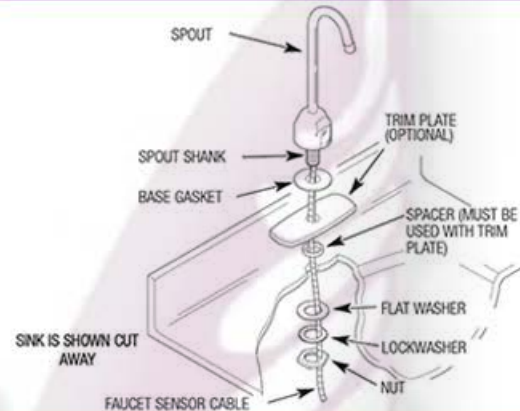

## 1B - INSTALL FAUCET SPOUT - EBF-550

### OPTIONAL ANTI-ROTATION FEATURE

**Note:** The anti-rotation feature uses a screw to anchor the faucet in the vertical position and is intended for use **ONLY** on stainless steel sinks.

- A** Place the Base Gasket over the faucet mounting hole using it as a template.
- B** Mark the stainless steel mounting surface at the center of the small hole at the bottom of the Base Gasket.

FAUCET MOUNTING HOLE OF  
STAINLESS STEEL SURFACE



DRILL 7/64" (3 mm) HOLE  
AT MARK PLACED ON  
STAINLESS STEEL  
MOUNTING SURFACE



STAINLESS STEEL  
MOUNTING SURFACE

SELF-TAPPING  
SCREW

BASE  
GASKET

- C** Drill a 7/64" (3 mm) diameter hole through the stainless steel mounting surface at the location just marked.
- D** After Faucet body is mounted, insert the Self-Tapping Screw through the drilled hole and into the small hole in the back of the Faucet body. Tighten the Screw.

**Note:** When installing the faucet with a Sloan mixing valve, both these Installation Instructions **AND** those packaged with the mixing valve **MUST** be followed.

### TO MOUNT ON SURFACE LESS THAN 0.41" (10 mm) THICK

- A** Route Sensor Cable through groove on side of Spout Shank.
- B** Insert Sensor Cable and Spout Shank through the Base Gasket and mounting hole of wall or sink.
- C** Secure Faucet with the Flat Washer, Lockwasher and Nut Supplied.

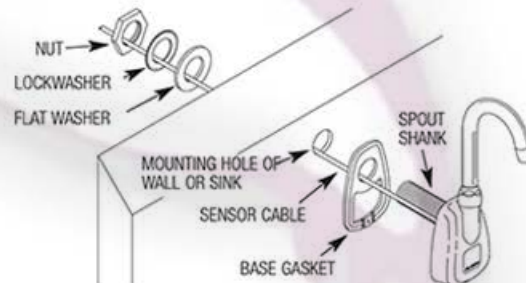

### TO MOUNT ON SURFACE BETWEEN 0.41" (10 mm) AND 1" (25 mm) THICK

- A** Screw Mounting Stud into end of Spout Shank.
- B** Route Sensor Cable through groove on side of Spout Shank.
- C** Insert Sensor Cable and Spout Shank through the Base Gasket and mounting hole of wall or sink.
- D** From behind wall, install Mounting Spacer onto Faucet Shank as illustrated. The Mounting Stud should protrude through the smaller hole of the Mounting Spacer.
- E** Secure using the Flat Washer, Lockwasher and Hex Jam Nut supplied. Do NOT overtighten the Hex Jam Nut.

**Note:** Sloan Valve Company does **NOT** supply hardware necessary for mounting the Faucet on surfaces thicker than 1" (25 mm).

- F** Install Male Connector into Spout Shank.

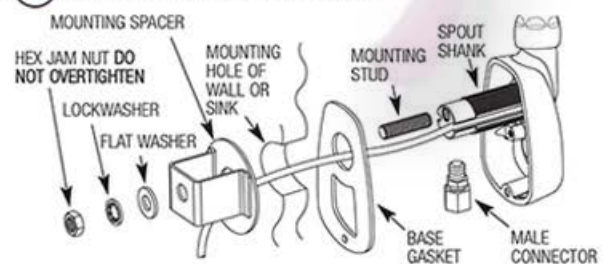

## 2 - Install Solenoid Valve (Models EBF-550 and EBF-750)

- A** Thread Male Connector into inlet hole at bottom of Spout Shank if not already installed. Tighten Male Connector securely to prevent leaks.

Model  
EBF-550

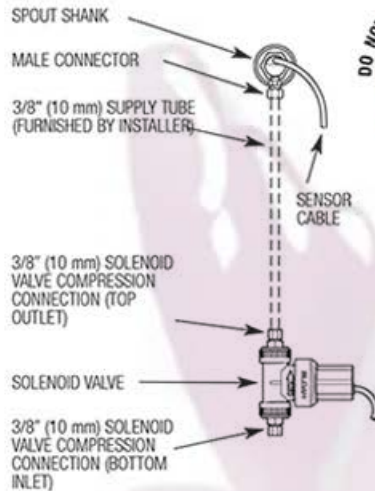

- B** Connect 3/8" (10 mm) supply tube (furnished by installer) between the Compression Fittings on Spout and top outlet of Solenoid Valve.

Flow direction of Solenoid Valve is indicated by an arrow on Valve Body.



- A** Install the 3/8" (10 mm) Straight Compression Fitting onto the Spout's copper Supply Tube.

- B** Connect 3/8" (10 mm) supply tube (furnished by installer) between the Compression Fittings on Spout and top outlet of Solenoid Valve.

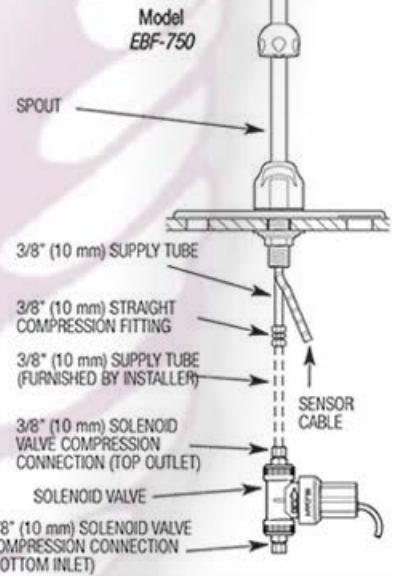

## 3 - Connect Supply Line(s) from Supply Stop(s) to Solenoid Valve Inlet

**Important:** Keep thread sealant out of your waterway and prevent component part damage! Do not use sealant on compression fittings. When thread sealant is used, do not apply it to the first two "starter" threads.

**Important:** Flush dirt, debris, and sediment from the supply line(s).

- A** **Dual Line Hot and Cold Water Supply Applications**  
Install a 3/8 inch (10 mm) copper supply tube between Bak-Chek® Compression Tee and hot and cold supply stops. (Supply tubes and stops furnished by installer.) Install a 3/8 inch (10 mm) copper supply tube between Bak-Chek Compression Tee and inlet side of Solenoid Valve. Tighten Compression Fittings securely.

**Note:** Failure to install the Bak-Chek® Tee can result in a cross flow connection when the faucet is off and the supply stops are open. If pressure of the hot and cold water supply differ, hot water can migrate into the cold water supply or vice-versa. Most plumbing codes require that the Bak-Chek® be used to prevent this.

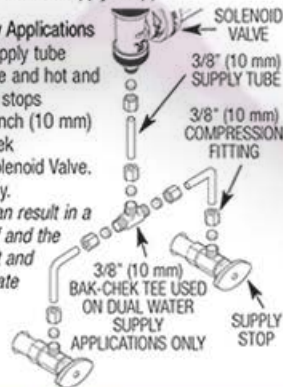

- B** **Single Line Water Supply Applications**  
Install a 3/8 inch (10 mm) copper supply tube between the supply stop and inlet side of Solenoid Valve. (Supply tube and supply stop furnished by installer.) Tighten Compression Fittings securely.

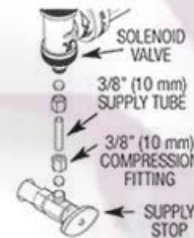

## 4 - Mount Control Module to Wall

- A** Install the Control Module in an appropriate location. Control Module must be installed so that all cables enter from the bottom of the unit. When installed, Cables from the Spout and Solenoid Valve to the Control Module should have some slack.

- B** Mount Control Module to wall using Mounting Screws and Plastic Anchors.

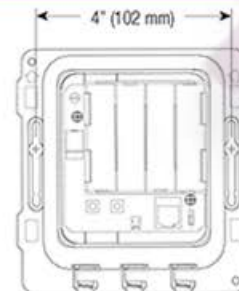

## 5 - Control Module Connection

- A** Route Cables from Solenoid Valve and Spout to the Control Module.
- B** Insert Locking Connector from Solenoid Valve into mating Receptacle.
- C** Insert Connector from Faucet Spout into Modular Receptacle.
- D** Insert Power Cable Jack from Transformer (optional) into Receptacle.
- E** Insert each Cable into a Strain Relief Slot.

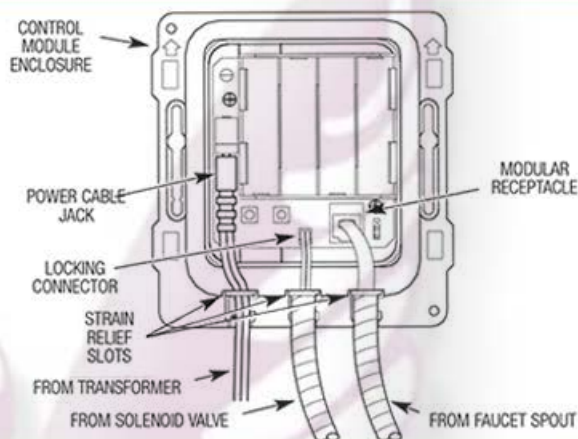

## 6 - Install Batteries and Plug in Adapter (Optional)

- A** Insert four (4) AA-size Alkaline Batteries provided as indicated by the (+) and (-) symbols inside the Battery Compartment.

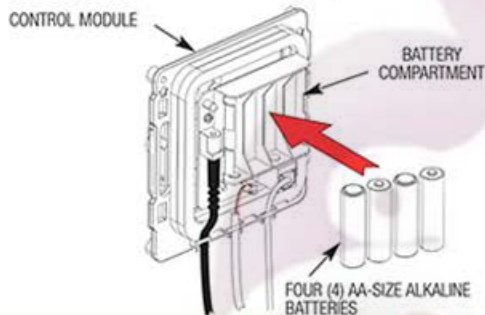

- B** Plug Adapter (optional) into Receptacle.



## 7 - Start-Up

- A** Activate ("dry fire") Faucet by placing hands in front of the Sensor. The Solenoid Valve should "click." Once hands are removed the Solenoid Valve should click again. If this does not occur, refer to the Troubleshooting section of this instruction manual. Once "dry firing" segment is complete, remove Aerator or Shower Spray Head. Open supply stop(s) then activate Faucet by placing hands in front of the Sensor. The Solenoid Valve should "click" and water should flow from the Spout.
- B** Activate Faucet for 30 seconds by placing hands in front of the Sensor. The Solenoid Valve should "click" and water should flow from the Spout. If this does not occur, refer to the Troubleshooting section of this installation instructions.
- C** Close supply stop(s) and reinstall Aerator or Spray Head in Spout. Reopen supply stop(s), activate Faucet and check for leaks.

## 8 - Range Adjustment

The OPTIMA Plus EBF-550 and EBF-750 Faucets are factory set to operate when hands are placed 4 to 5 inches (102 to 127 mm) from Sensor. This range should be satisfactory for most installations. If range adjustment is required, refer to the following range adjustment procedure.

- A** The Range Potentiometer is located in the Control Module.

**Important:** Range Potentiometer adjustment screw rotates only 3/4 of a turn; DO NOT over-rotate. Over-rotating will damage range adjustment screw.

- B** Cycle Faucet several times to assure that the Sensor will not inadvertently pick up reflection off the edge of the sink. If reflection occurs, adjust Range Potentiometer counterclockwise very slightly and again cycle Faucet. Repeat adjustment procedure until desired range is achieved.

- C** CLOCKWISE INCREASES RANGE  
**C** COUNTERCLOCKWISE DECREASES RANGE

A SCREWDRIVER IS PROVIDED ON THE INSIDE COVER OF THE CONTROL MODULE FOR MAKING RANGE ADJUSTMENTS

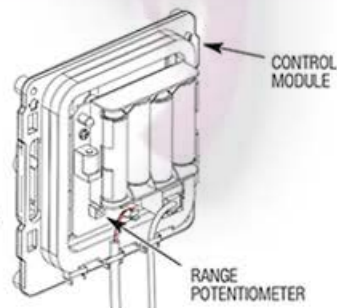

## 9 - Noise Reduction (NR) and Time Out (Mode) Jumper Settings

For jumper settings, refer to Table below or label on cover of Control Module along with the instructions in this Step.

### Noise Reduction (NR) Setting

- When operating the faucet on batteries alone, set the NR jumper to bridge pins 1 and 2.
- When operating the faucet using the plug-in transformer with battery backup, bridge pins 2 and 3.

### Time Out (Mode) Setting

The Faucet Time Out Setting determines the maximum time the Faucet will run upon continuous activation. This timing can be changed to meet individual application requirements.

Unless otherwise specified, Faucets leave the factory set with a 30 second Time Out.

DESCRIPTION	PINS		
	1	2	3
<b>NOISE REDUCTION (NR) SETTING</b>			
NR Enabled (Adapter w/Battery Backup Operation)	●	●	
Normal Operation (Battery Operation Only)		●	●
<b>TIME OUT (MODE) SETTING</b>			
13.75 Second On Demand	●	●	
30 Second On Demand		●	●

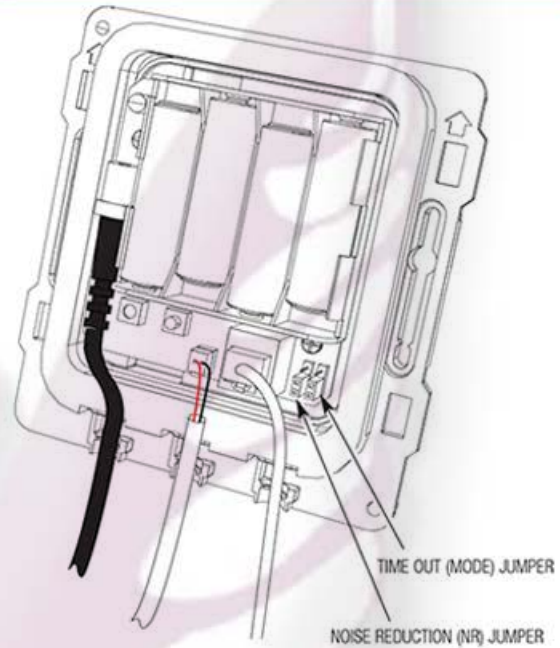

## 10 - Install Cover onto Control Module

- A** Install Cover over the Control Module making sure that all four (4) locking tabs snap into place. Secure using the two (2) screws provided. Cover can be installed in only one orientation.

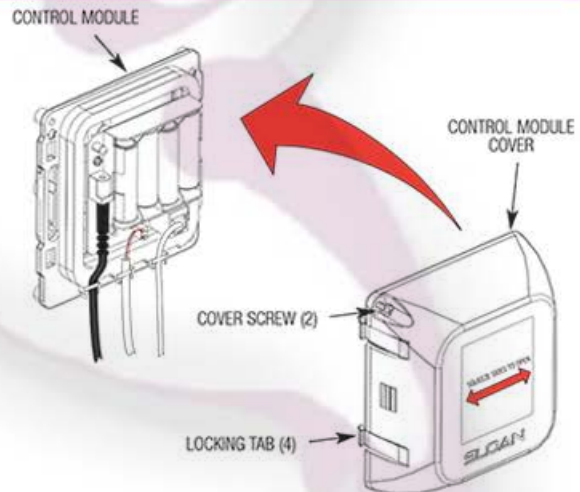

## Operation

1. A continuous invisible beam of infrared light is emitted from the OPTIMA® Sensor.
2. As the user's hands enter the beam's effective range, the beam is reflected back into the sensor receiver and activates the solenoid valve allowing water to flow from the faucet. Water will flow until the hands are removed or until the faucet reaches its automatic time out limit setting.
3. When hands are moved away from the OPTIMA® Sensor, the loss of reflected light initiates an electrical signal that deactivates the Solenoid Valve, shutting off the water flow. The Circuit then automatically resets and is ready for the next user.

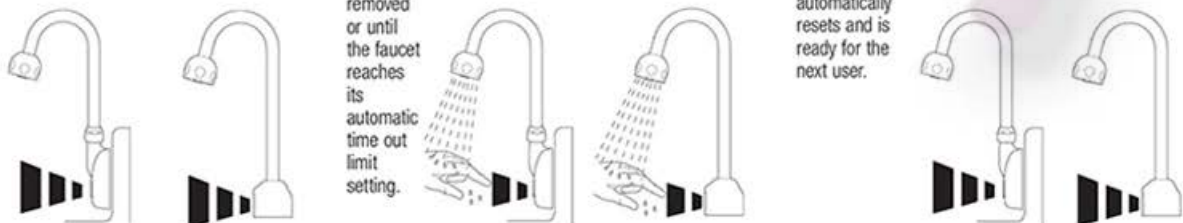

## Care and Cleaning of Chrome and Special Finishes

**DO NOT USE** abrasive or chemical cleaners (including chlorine bleach) to clean faucets that may dull the luster and attack the chrome or special decorative finishes. Use **ONLY** soap and water, then wipe dry with clean cloth or towel.

While cleaning the bathroom tile, protect the faucet from any splattering of cleaner. Acids and cleaning fluids will discolor or remove chrome plating.



## Battery Replacement Procedure (Water Does NOT Need to be Turned Off)

The Sloan Optima Plus EBF-550 and EBF-750 faucets are furnished with four (4) AA-size alkaline batteries that provide up to two (2) years of operation (8000 cycles per month). A flashing LED signal indicates that battery power will be depleted within one (1) month.

- A** Remove Cover as follows:
1. Remove the two (2) Cover Screws.
  2. Press in the middle of both sides.
  3. Pull Cover straight out from Control Module Base.

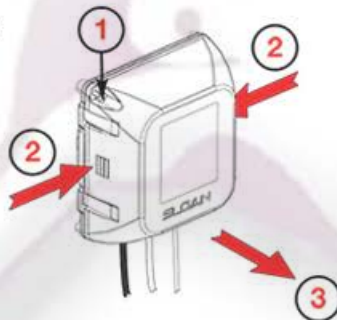

- B** Remove old batteries and insert four (4) new AA-size Alkaline Batteries as indicated by the (+) and (-) symbols inside the Battery Compartment.

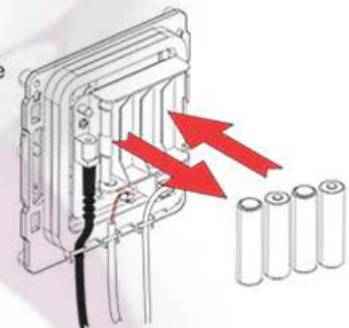

- C** Reinstall Cover. Refer to Step 10.

## Solenoid Screen Filter Cleaning Procedure

- A** Turn off water supply at supply stop(s). Activate Faucet to relieve system pressure.
- B** Remove Water Supply Line from Inlet Side of Solenoid Valve. Remove Cap, Water Line Fitting, Gasket, Filter Housing and Filter from Solenoid Valve Housing.
- C** Slide Filter off Filter Housing. Clean Filter using fresh tap water only. If necessary, use a small brush to clean. Use caution while cleaning to prevent damage to Filter. If any Filter components are damaged, replace as necessary. Examine the Gasket for wear or damage; replace if necessary.

- D** Reinstall Filter on Filter Housing. Install Filter Housing, Water Line Fitting, Gasket and Cap onto Solenoid Valve Housing. Tighten Cap securely.

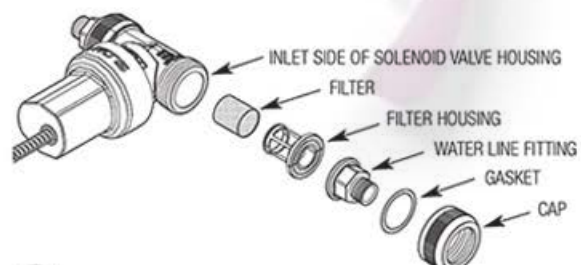

- E** Reinstall Water supply Line to Inlet Side of Solenoid Valve.



## Troubleshooting Guide

1. **PROBLEM:** Sensor LED does not function (indicator light on sensor window in faucet spout does not flash during initial 10 minute set-up mode).  
*CAUSE:* There is no visible indicator light. Normal operation.  
*SOLUTION:* This is a normal operating feature of the faucet.
2. **PROBLEM:** Faucet does not deliver any water when Sensor is activated.  
*INDICATOR:* Solenoid valve produces audible "CLICK."  
*CAUSE:* Water supply stop(s) closed.  
*SOLUTION:* Open supply stop(s) completely.  
*INDICATOR:* Solenoid valve DOES NOT produce an audible "CLICK."  
*CAUSE:* Solenoid Lead is not properly connected to the Control Module.  
*SOLUTION:* Disconnect and reconnect Solenoid Lead to Control Module.  
*CAUSE:* No battery or Transformer power is being supplied to Sensor.  
*SOLUTION:* Ensure that the batteries are installed properly. Check that the orientation of each battery matches the positive (+) and negative (—) symbols shown at bottom of battery compartment. Reinsert Batteries into Control Module. Transformer (optional) is unplugged or wall receptacle has no power.  
*CAUSE:* Sensor Cable is not properly connected to the Control Module.  
*SOLUTION:* Disconnect and reconnect Sensor Cable to Control Module.  
*CAUSE:* Sensor range is set at minimum distance.  
*SOLUTION:* Increase Sensor range. Refer to Step 8, Range Adjustment.  
*CAUSE:* Control Module assembly is defective.  
*SOLUTION:* Replace Control Module assembly.
3. **PROBLEM:** Faucet delivers only a slow flow or dribble when Sensor is activated.  
*CAUSE:* Water supply stop(s) partially closed.  
*SOLUTION:* Open supply stop(s) completely.  
*CAUSE:* Solenoid Filter is clogged.  
*SOLUTION:* Remove, clean and reinstall Filter. Refer to Solenoid Screen Filter Cleaning Procedure on Page 7.  
*CAUSE:* Aerator or Spray Head is clogged.  
*SOLUTION:* Remove, clean and reinstall Aerator or Spray Head.
4. **PROBLEM:** Faucet does not stop delivering water or continues to drip after user is no longer detected (automatic shut-off fails even when batteries are removed).  
*CAUSE:* Solenoid Valve has been connected backwards.  
*SOLUTION:* Disconnect Solenoid Valve compression fittings at both the inlet and outlet positions. The water should flow from inlet through the Solenoid Valve to the outlet according to the direction of the arrow shown on the side of the Solenoid Valve. Reconnect the compression fittings in the correct orientation.  
*CAUSE:* Solenoid Valve is dirty.  
*SOLUTION:* Backflush by reversing water flow (opposite to the direction shown by the arrow on the side of the Solenoid Valve) through the Solenoid Valve. Reconnect the compression fittings in the correct orientation. Activate faucet.  
*CAUSE:* Solenoid Valve Module is defective.  
*SOLUTION:* Replace Solenoid Valve Module.
5. **PROBLEM:** The water temperature is too hot or too cold on a faucet connected to hot and cold supply lines with Bak-Chek® Tee.  
*CAUSE:* Supply stops are not adjusted properly.  
*SOLUTION:* Adjust supply stops.  
*NOTE:* For some systems, a Thermostatic Mixing Valve may be required.
6. **PROBLEM:** Red LED turns on in the control module (below deck).  
*CAUSE:* One (or more) of the batteries is "dead."  
*SOLUTION:* To ensure proper operation, insert four (4) new AA-size Alkaline batteries. Check that the orientation of each battery matches the positive (+) and negative (—) symbols shown on the bottom of the battery compartment. Reinsert Batteries into the Control Module.  
*NOTE:* Upon start-up mode (1st ten minutes) the control module circuitry tests the batteries and the Red LED turns on if the battery voltage is low. No Red LED light indicates normal battery voltage.  
*NOTE:* If reset button is pressed (initiates start up mode/1st ten minutes), the battery voltage is checked. If voltage is too low, product is stopped from operating and Red LED will turn on. No Red LED light indicates normal battery voltage.
7. **PROBLEM:** Green LED initially turns on in the control module (below deck) during start up mode, then will not appear again.  
*CAUSE:* For the 1st ten minutes of operation (batteries inserted or reset button pressed) the Green LED will turn on when there is a target present (hands in front of sensor). After ten minutes, the Green LED will no longer turn on.  
*SOLUTION:* This is a normal operating feature of the faucet.

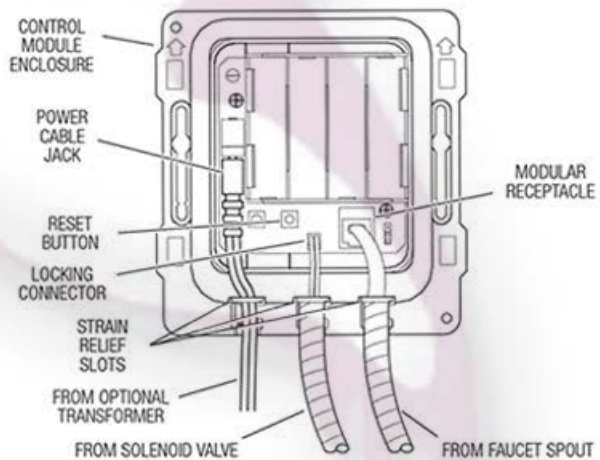



## Parts List

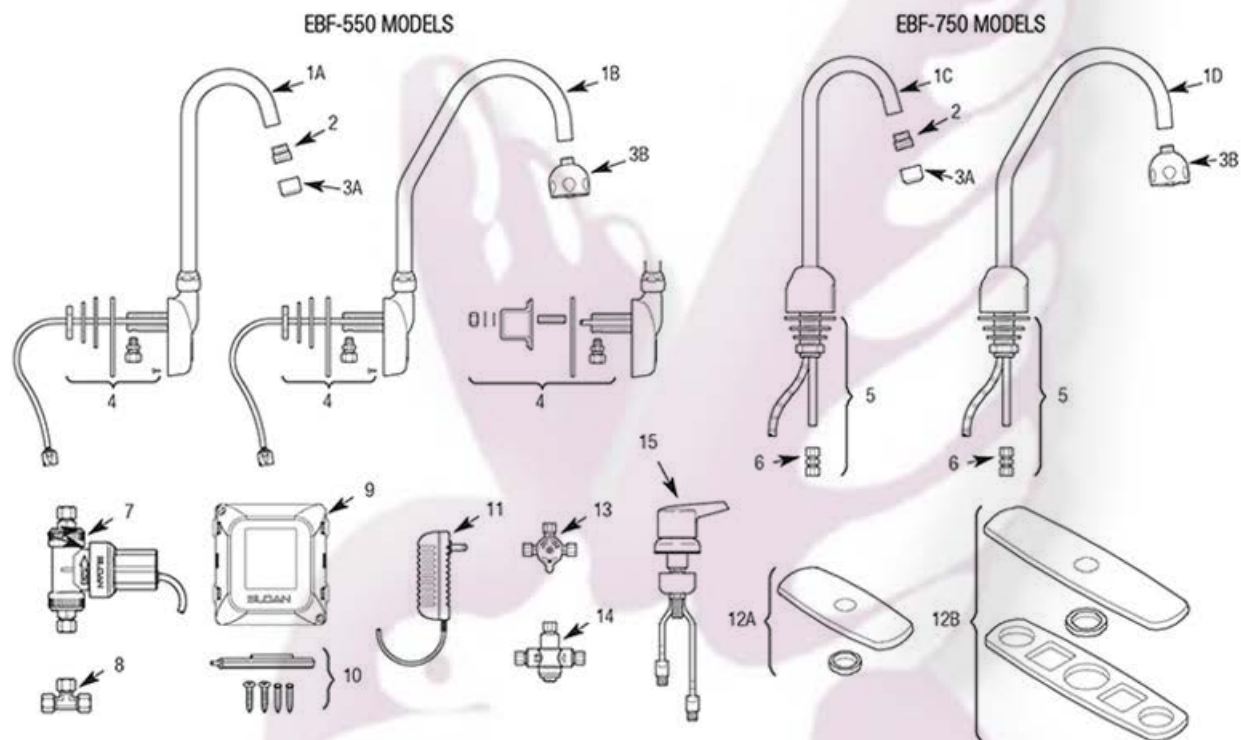

Item No.	Part No.	Description
1A	—	Faucet and Sensor Assembly, Standard (EBF-550)
1B	—	Faucet and Sensor Assembly with Surgical Bend (EBF-550-S)
1C	EBF-140-A	Faucet and Sensor Assembly, Standard (EBF-750)
1D	EBF-141-A	Faucet and Sensor Assembly with Surgical Bend (EBF-750-S)
2	ETF-178	Aerator Adapter (not required for Shower Spray Head)
3A	ETF-801	0.5 gpm (1.9 Lpm) Laminar Flow Spray Head
	ETF-687	1.5 gpm (5.7 Lpm) Laminar Flow Spray Head
	ETF-621	2.2 gpm (8.3 Lpm) Laminar Flow Spray Head
3B	AC-55-A	Shower Spray Head, 2.2 gpm (8.3 Lpm) Max.
4	EBF-110-A	Spout Mounting Kit (EBF-550), includes: Base Gasket, Flat Washer, Lockwasher, Mounting Nut, 1/8" NPT x 3/8" Tube Male Connector; 3/8"-24 Mounting Stud, Mounting Spacer, 3/8" Flat Washer, 3/8" Lockwasher, 3/8"-24 Hex Jam Nut, and #6 x 3/8" Self-Tapping Screw Type B
5	ETF-503-A	Spout Mounting Kit (EBF-750), includes: Base Gasket, Flat Washer, Lockwasher, Mounting Nut and ETF-530 Union Compression Fitting
6	ETF-530	3/8" x 3/8" Union Compression Fitting (EBF-750)
7	ETF-740-A	6 VDC Solenoid Assembly
8	ETF-617-A	3/8" Bak-Chek® Tee Compression Fitting
9	ETF-735-A	Control Module
10	ETF-443-A	Hardwired Mounting Kit (optional)
11	SFP-6	110 VAC/6 VDC Plug-in Adapter (optional)

Item No.	Part No.	Description
<b>OPTIONAL TRIM PLATES</b>		
12A	ETF-312-A	4" (102 mm) Centerset Single-hole Trim Plate Kit (Faucet only)
12B	ETF-431-A	8" (204 mm) Centerset Single-hole Trim Plate Kit (Faucet only)
—	MIX-102-A	8" (204 mm) Centerset Double-hole Trim Plate Kit with Optional Mixing Valve (EBF-750 only)
<b>OPTIONAL MIXING VALVES</b>		
13	MIX-60-A	Below Deck Mechanical Water Mixing Valve (BDM Variation)
14	MIX-135-A	Below Deck Thermostatic Water Mixing Valve (BDT Variation)
15	MIX-110-AA	Optimix® Deck Mounted Water Mixing Valve (EBF-750 only)
<b>SENSOR REPLACEMENT KIT</b>		
	EBF-107-A	(EBF-550)
	EBF-138-A	(EBF-750)
<b>CONTROL MODULE REPLACEMENT GASKETS</b>		
	ETF-736	(2 Required)

