

SLOAN[®]
Water Connects Us™

NAVAL[®]
INSTALLATION INSTRUCTIONS
PISTON TYPE FLUSHOMETER
FOR EXPOSED CLOSET AND URINAL
INSTALLATIONS

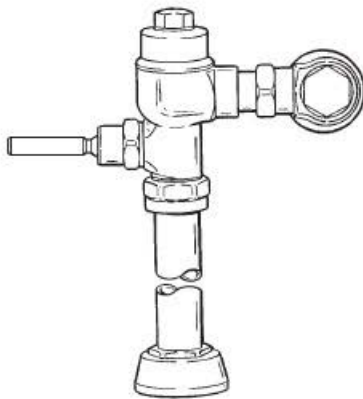

**Exposed Closet Flushometer —
1-1/2" Top Spud**
NAVAL 110/111
NAVAL 115
NAVAL 116

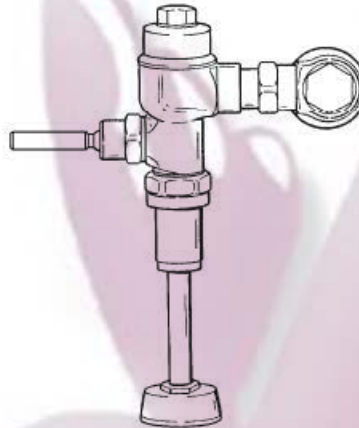

**Exposed Urinal Flushometer —
1-1/4" Top Spud**
NAVAL 180
**Exposed Urinal Flushometer —
3/4" Top Spud**
NAVAL 186

SR[®] Certified

Made in the U.S.A

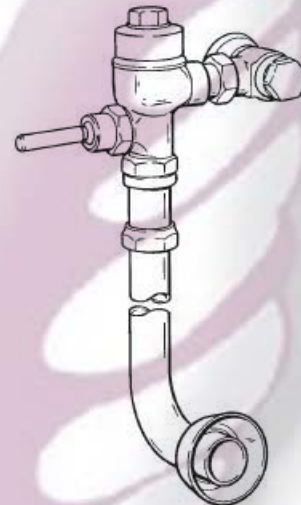

**Exposed Closet Flushometer —
1-1/2" Back Spud**
NAVAL 120
NAVAL 121
NAVAL 122

The Sloan Naval[®] is a piston type Flushometer of superior design. It employs an exclusive Xpelor By-Pass Feature that ensures consistent metering operation even under the most severe water conditions. Naval Brass, Stainless Steel and High Grade Thermoplastics insure that vital inside parts will not be affected by corrosive water conditions. The Naval is especially suited for marine use, gray water systems or any other application where aggressive or corrosive water conditions would reduce the life and efficiency of an ordinary flushometer.

The Naval Flushometer is designed for easy installation and maintenance and

comes complete with a metal oscillating Non-Hold-Open lever actuator, Bak-Chek[®] control stop, adjustable tailpiece (ground joint tailpiece available for salt water applications), vacuum breaker flush connection, spud coupling, and wall and spud flanges.

The following instructions will serve as a guide when installing the Sloan Naval Flushometer. As always, good safety practices and care are recommended when installing your new Flushometer. If further assistance is required, contact your nearest Sloan Representative office.

LIMITED WARRANTY

Sloan Valve Company warrants its Naval Flushometer to be made of first class materials, free from defects of material or workmanship under normal use and to perform the service for which they are intended in a thoroughly reliable and efficient manner when properly installed and serviced, for a period of three years (1 year for special finishes) from date of purchase. During this period, Sloan Valve Company will, at its option, repair or replace any part or parts which prove to be thus defective if returned to Sloan Valve Company, at customer's cost, and this shall be the sole remedy available under this warranty. No claims will be allowed for labor, transportation or other incidental costs. This warranty extends only to persons or organizations who purchase Sloan Valve Company's products directly from Sloan Valve Company for purpose of resale.

THERE ARE NO WARRANTIES WHICH EXTEND BEYOND THE DESCRIPTION ON THE FACE HEREOF. IN NO EVENT IS SLOAN VALVE COMPANY RESPONSIBLE FOR ANY CONSEQUENTIAL DAMAGES OF ANY MEASURE WHATSOEVER.



VALVE ROUGH-IN

NAVAL 110 — Water Saver, 3.5 gpf (13.2 Lpf)
NAVAL 111 — Low Consumption, 1.6 gpf (6.0 Lpf)

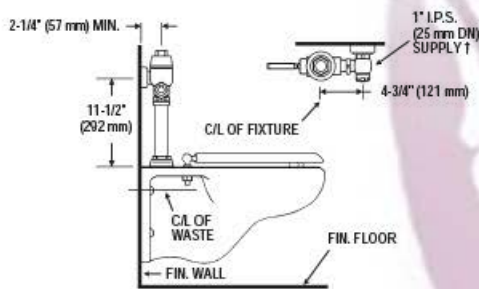

† 1" CONTROL STOP IS AVAILABLE WITH WHITWORTH THREAD

NAVAL 115 & 116 — Water Saver, 3.5 gpf (13.2 Lpf)
NAVAL 115-1.6 & 116-1.6 — Low Consumption, 1.6 gpf (6.0 Lpf)

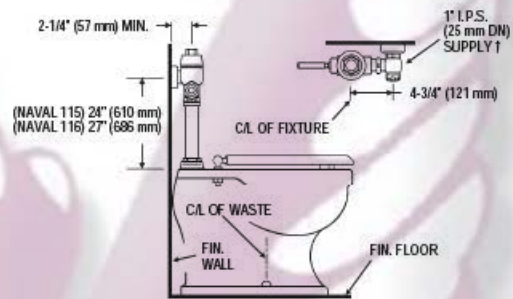

† 1" CONTROL STOP IS AVAILABLE WITH WHITWORTH THREAD

NAVAL 120, 121 & 122 — Water Saver, 3.5 gpf (13.2 Lpf)
NAVAL 120-1.6, 121-1.6 & 122-1.6 — Low Consumption, 1.6 gpf (6.0 Lpf)

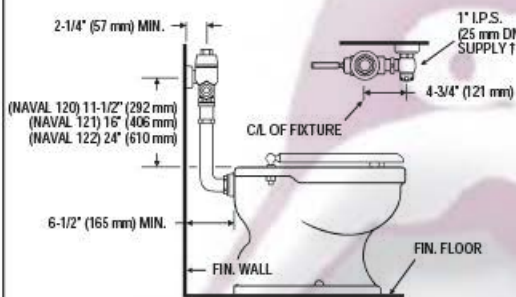

† 1" CONTROL STOP IS AVAILABLE WITH WHITWORTH THREAD

NAVAL 180-1 — Low Consumption, 1 gpf (3.8 Lpf)

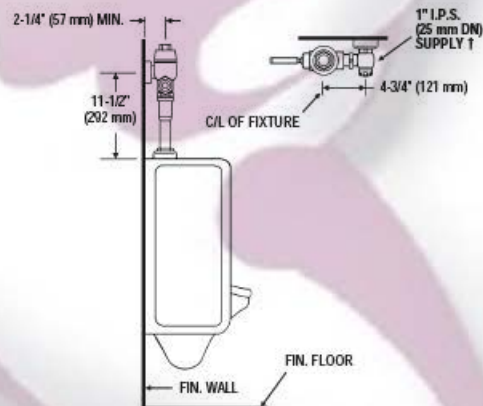

† 1" CONTROL STOP IS AVAILABLE WITH WHITWORTH THREAD

MODEL 186-1 — Low Consumption, 1 gpf (3.8 Lpf)

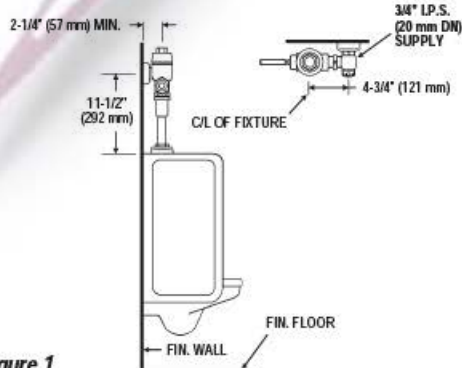

Figure 1

For Salt Water applications, Sloan Valve Company recommends furnishing Naval Valves with a Ground Joint Supply Stop. Specify "-GJ" (Ground Joint) variation.

Salt Water and other non-potable water supplies typically do not require the use of vacuum breakers. To furnish the valves less the vacuum breaker, specify the "-XYV" variation.

FLUSH VOLUMES NOTED ABOVE ARE FACTORY SET.

VALVE FLUSH VOLUME ADJUSTMENT RANGE

Urinal:	0.5 to 3 gpf (1.9 to 11.4 Lpf)
Clonet:	1.5 to 7 gpf (5.7 to 26.5 Lpf)



PRIOR TO INSTALLATION

Prior to installing the Sloan Navel Flushometer, install the items listed below as illustrated in Figure 1.

- Closet/urinal fixture
- Drain line
- Water supply line

Important:

- ALL PLUMBING IS TO BE INSTALLED IN ACCORDANCE WITH APPLICABLE CODES AND REGULATIONS.
- WATER SUPPLY LINES MUST BE SIZED TO PROVIDE AN ADEQUATE VOLUME OF WATER FOR EACH FIXTURE.
- FLUSH ALL WATER LINES PRIOR TO INSTALLING FLUSHOMETER

The Sloan Navel® is designed to operate with 10 to 100 psi (69 to 689 kPa) of water pressure. THE MINIMUM PRESSURE REQUIRED TO THE VALVE IS DETERMINED BY THE TYPE OF FIXTURE SELECTED. Consult fixture manufacturer for minimum pressure requirements.

Most Low Consumption water closets (1.6 gallon/6 liter) require a minimum flowing pressure of 25 psi (172 kPa).

Protect the Chrome or Special finish of this flushometer — DO NOT USE TOOTHED TOOLS TO INSTALL OR SERVICE THE VALVE. Also, see "Care and Cleaning" section of this manual.

IMPORTANT: WITH THE EXCEPTION OF CONTROL STOP INLET, DO NOT USE PIPE SEALANT OR PLUMBING GREASE ON ANY VALVE COMPONENT OR COUPLING!

TOOLS REQUIRED FOR INSTALLATION

- Slotted screwdriver
- Sloan A-50 "Super-Wrench™" or smooth jawed spud wrench

INSTALLATION

Step 1 - Control Stop Installation (Figure 2)

Install the Sloan Bak-Chek® Control Stop and Supply Flange to the water supply

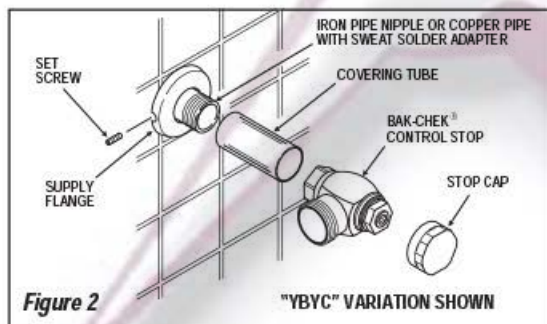

line with the outlet positioned as required.

For Sweat Solder applications, see the following instructions & Figure 3:

- Measure distance from finished wall to centerline of Fixture Spud. Cut water supply pipe 1-1/4" (32 mm) shorter than this measurement. Chamfer O.D. and I.D. of water supply pipe.
- Slide Threaded Adapter onto water supply pipe until end of pipe rests against shoulder of Adapter. Sweat solder Adapter to water supply pipe.
- Determine length of Covering Tube by measuring distance from finished wall to the first thread of Adapter (dimension "X" in Figure 3). Cut Covering Tube to this length.
- Slide Covering Tube onto water supply pipe. Slide Wall Flange over Covering Tube until it rests against the finished wall.
- Install the Sloan Bak-Chek® Control Stop to the water supply line with the

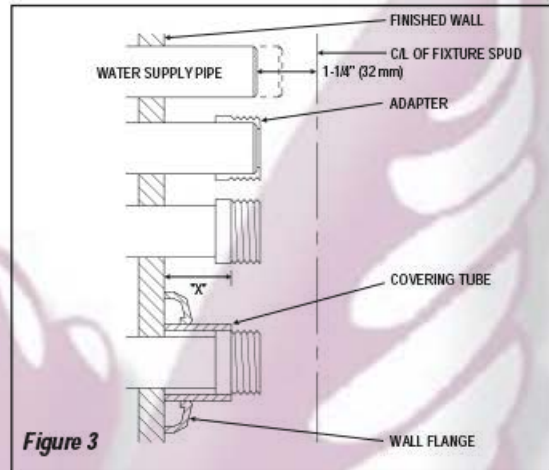

Figure 3

outlet positioned as required.

Step 2 - Install Vacuum Breaker Flush Connection (Figure 4)

Slide the Spud Coupling, Nylon Slip Gasket, Rubber Gasket and Spud Flange over the Vacuum Breaker Tube and insert tube into Fixture Spud. Hand tighten Spud Coupling onto Fixture Spud.

Note: On valves furnished less vacuum breaker, (XYV variation), connect flush

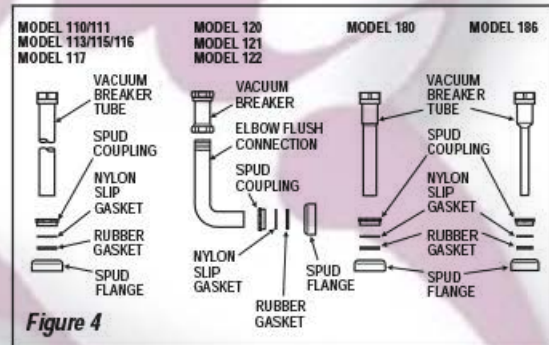

Figure 4

tube to the bottom of the valve using the slip gasket supplied.

Step 3 - Install Flushometer SLOAN ADJUSTABLE TAILPIECE (Figure 5)

The Sloan Adjustable Tailpiece compensates for "off-center" roughing-in on the job. Maximum adjustment is 1/2" (13 mm) IN or 1/2" (13 mm) OUT from the standard 4-3/4" (121 mm) (centerline of Flushometer to centerline of Control Stop).

If a ground joint tailpiece has been specified (recommended for seawater applications), there is no lateral adjustment; therefore, the 4-3/4" (121 mm)

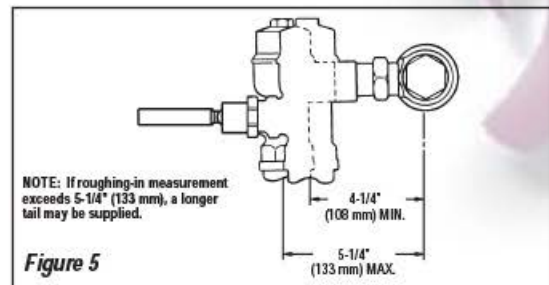

Figure 5



rough-in must be exact.

IMPORTANT: WITH THE EXCEPTION OF CONTROL STOP INLET, DO NOT USE PIPE SEALANT OR PLUMBING GREASE ON ANY VALVE COMPONENT OR COUPLING!

Sloan Adjustable Tailpiece — Insert Adjustable Tailpiece into Control Stop. Wet O-ring seal with water to lubricate. Secure by hand tightening Tailpiece Coupling.

Sloan Ground Joint Tailpiece — Place end of tailpiece against control stop. Secure by hand tightening tailpiece coupling.

All Flushometers — Align Flushometer on top of Vacuum Breaker Flush Connection and secure by hand tightening Vacuum Breaker Coupling.

Align Flushometer Body and securely tighten Tailpiece Coupling, Vacuum Breaker Coupling and Spud Coupling, respectively.

Important Note: Use a Sloan A-50 "Super-Wrench™" or smoothjawed spud wrench to secure all couplings. This will eliminate damage to chrome or special finish that normally occurs when slip-joint pliers, pipe wrenches or other "toothed" tools are used.

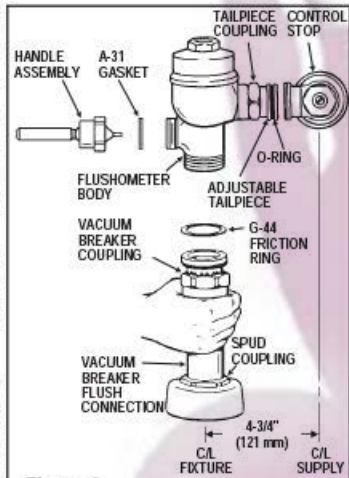

Figure 6

Step 4 - Flush Out Supply Line (Figure 7)

Shut off Control Stop and remove Flushometer Cover. Lift out the Piston Assembly. Install Flushometer Cover wrench tight and open Control Stop. Turn on water supply to flush line of any debris or sediment.

After completion, shut off Control Stop, remove Flushometer Cover and reinstall Piston Assembly. Install Flushometer Cover wrench tight. Open Control Stop and

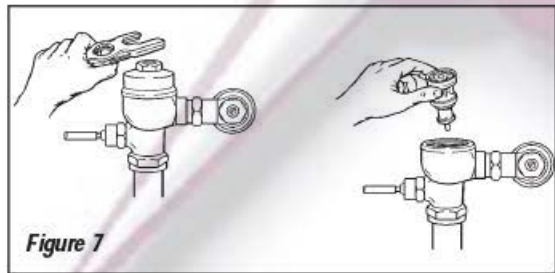

Figure 7

activate Flushometer Valve.

Step 5 - Adjust Control Stop (Figure 8)

Adjust Control Stop to meet the flow rate required for the proper cleansing of the fixture. Open Control Stop COUNTERCLOCKWISE 1/2 turn from the closed position. Activate Flushometer. Adjust Control Stop after each flush until the rate of flow delivered properly cleanses the fixture.

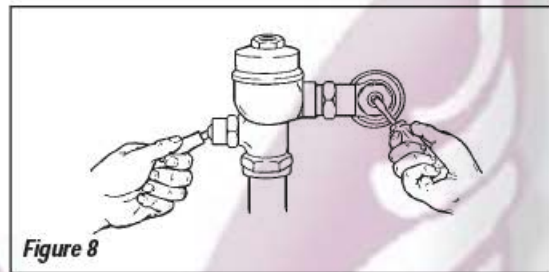
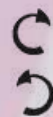

Figure 8

Step 6 - Volume Adjustment (Figure 9)

The Sloan Naval Flushometer can be adjusted to meet the flushing requirements of any plumbing fixture. The flush volume (gallons per flush) may be increased or decreased by turning the adjustment screw located beneath the hex nut in the center of the cover.



CLOCKWISE reduces flush volume

COUNTERCLOCKWISE increases flush volume

ADJUSTMENT RANGE: Urinal: 0.5 to 3 gpf (1.9 to 11.4 Lpf)
Closet: 1.5 to 7 gpf (5.7 to 26.5 Lpf)

Important: Many local plumbing codes prohibit adjustable Flushometers. For these applications, the Naval Flushometer can be supplied in a non-adjustable style.

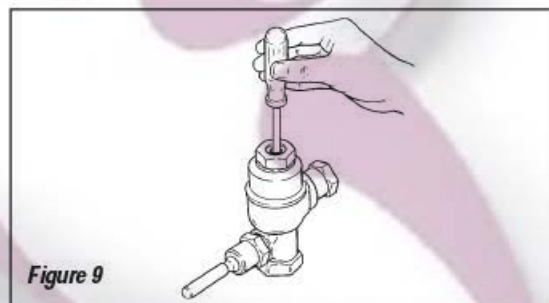

Figure 9

Important: The Sloan NAVAL Flushometer is engineered for quiet operation. Excessive water flow creates noise, while too little water flow may not satisfy the needs of the fixture. Proper adjustment is made when:

1. The plumbing fixture is cleansed after each flush without splashing water out from the lip.
2. A quiet flushing cycle is achieved.

After adjustment: Wrench Tighten Control Stop Cap to Eliminate Vandalism.

CARE AND CLEANING OF CHROME AND SPECIAL FINISHES

DO NOT use abrasive or chemical cleaners to clean Flushometers as they may dull the luster and attack the chrome or special decorative finishes. Use ONLY soap and water, then wipe dry with clean cloth or towel.

While cleaning the bathroom tile, the Flushometer should be protected from any splattering of cleaner. Acids and cleaning fluids can discolor or remove chrome plating.



TROUBLESHOOTING GUIDE

I. Valve does not function.

- A. Control Stop or Main Valve is Closed. Open Control Stop or Main Valve.
- B. Handle Assembly is worn. Install Handle Repair Kit (B-50-A) or replace handle.

II. Insufficient volume of water to adequately siphon fixture.

- A. Control Stop not open enough. Adjust Control Stop for desired delivery of water.
- B. Urinal or Shower Piston installed in a Closet Valve or older Blow Out Urinal. Replace Piston with proper Closet Piston (CN-1002-A).
- C. Regulating Screw (on top of valve) improperly set. Turn Regulating Screw counterclockwise to increase flush.

VALVE FLUSH VOLUME ADJUSTMENT RANGE —

Urinal: 0.5 to 3 gpf (1.9 to 11.4 Lpf)
Closet: 1.5 to 7 gpf (5.7 to 26.5 Lpf)

- D. Piston worn out. Repair or replace Piston.
- E. Inadequate volume or pressure at supply. If no gauges are available to properly measure supply pressure or volume of water at the Valve, then completely remove the entire Piston from the valve, reassemble cover and open Control Stop to allow water to pass through the empty Valve. If the supply is adequate to siphon the fixture, remove the Flow Ring from the bottom of the Piston to provide additional flow. If the supply is not adequate to siphon the fixture, steps should be taken to increase the pressure and/or supply.

III. Length of flush too short (Short Flushing) or Valve closes off immediately.

- A. Regulating Screw not at a proper setting. Turn Regulating Screw counterclockwise to lengthen flush.
- B. Water passing by damaged or worn Piston Cup. Repair or replace Piston.
- C. Loose Piston Assembly or loose Top Plate Screw. Tighten Top Plate Screws. Screw Piston Body and Guide together (hand tighten ONLY - rubber Relief Valve Seat will distort if screwed too tight).
- D. Damaged or worn Piston Top Plate or Expelor. Repair or replace Piston.
- E. Urinal or Shower Piston installed in a Closet Valve or older Blow Out Urinal. Replace Piston with Closet Piston (CN-1002-A).

IV. Length of flush too long (Long Flushing) or fails to close off.

- A. Regulating Screw not at proper setting. Turn Regulating Screw clockwise to shorten flush.
- B. Relief Valve in Piston is not seating properly due to wear or debris. Disassemble Piston Assembly and wash under running water. Repair or replace Piston if necessary.
- C. Bypass holes in Piston or Top Plate clogged or fouled with debris. Disassemble Piston Assembly and wash under running water. Repair or replace Piston if necessary.
- D. Closet Piston installed in Urinal Valve. Replace Piston with Urinal Piston (CN-1003-A).
- E. Line has dropped and is not sufficient to force Relief Valve to Seat. Shut off Control Stop until pressure has been restored, then reopen Stop.

V. Water splashes from fixture.

- A. Supply volume is more than necessary. Adjust Control Stop to meet flow rate required for proper cleansing of the fixture.
- B. Lime or mineral accumulation on fixture vortex or spreader holes. Remove lime or mineral build-up in fixture.

VI. Flush is not considered "Quiet" or makes noise at close off.

- A. Control Stop not properly adjusted. Adjust Control Stop to meet flow rate required for proper cleansing of the fixture.
- B. Worn, damaged or loose Main Seat. Replace Main Seat.
- C. Worn Piston. Repair or replace Piston.

VII. Leaking at Handle Assembly.

- A. The B-39 Handle Seal may be deteriorated. Install new B-39 Handle Seal. NOTE: The B-39 Seal will easily slide onto the Bushing if it is wet.
- B. Handle Gasket has been omitted. Install A-31 Handle Gasket or Handle Repair Kit (B-50-A).
- C. Valve Handle Bushing is worn. Install Handle Repair Kit (B-50-A).



PARTS LIST

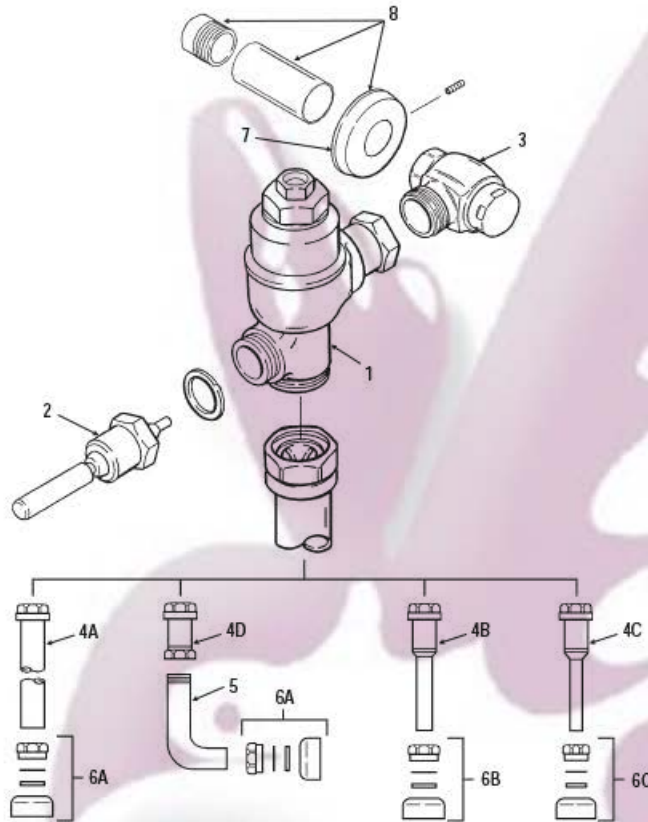

Item No.	Part No.	Description
1	†	Valve Assembly
2	B-32-A	Handle Assembly
3	H-710-A	Bak-Chek® Control Stop
4A	V-500-AA	1-1/2" (38 mm) x 9" (229 mm) Vacuum Breaker Assembly CP (Model 110)
	V-500-AA	1-1/2" (38 mm) x 21" (533 mm) Vacuum Breaker Assembly CP (Model 115)
	V-500-AA	1-1/2" (38 mm) x 24" (610 mm) Vacuum Breaker Assembly CP (Model 116)
4B	V-500-AA	1-1/4" (32 mm) x 9" (229 mm) Vacuum Breaker Assembly CP (Model 180)
4C	V-500-AA	3/4" (19 mm) x 9" (229 mm) Vacuum Breaker Assembly CP (Model 186)
4D	V-500-A	1-1/2" (38 mm) Vacuum Breaker Assembly CP
5	F-109	1-1/2" (38 mm) Elbow Flush Connection CP
6A	F-5-A	1-1/2" (38 mm) Spud Coupling Assembly (Models 110, 115, 116, 120, 121 and 122)
6B	F-5-A	1-1/4" (32 mm) Spud Coupling Assembly (Model 180)
6C	F-5-A	3/4" (19 mm) Spud Coupling Assembly (Model 186)
7	F-7	Supply Flange (Supplied When Valve is Not Ordered with Sweat Solder Kit)
8	H-633-AA	1" (25 mm) Sweat Solder Kit with Cast Set Screw Flange ("YBYC" Variation)
	H-636-AA	3/4" (19 mm) Sweat Solder Kit with Cast Set Screw Flange ("YBYC" Variation)

† Part number varies with valve model variation; consult factory.

