

FAUCET DESCRIPTION

- Brass construction with chrome plated finish
- 1/2" IPS connections
- 8" centers
- Vandal resistant torx head screws

OPERATION

- Wrist blade style handles with hot and cold color indicators

FLOW

- 2.2 gpm max (8.3 L/min) at 60 psi

CARTRIDGE

- Brass shell, ceramic disc cartridge
- 1/4 turn operation

STANDARDS

- Third party certified to CSA B-125.1, ASME A112.18.1, ICC A117.1 and all applicable specifications referenced therein including NSF 61/9
- Complies with California Proposition 65 and with the Federal Safe Drinking Water Act
- ADA ♿ for lever handles

WARRANTY

- Warranted for five years against material or manufacturing defects

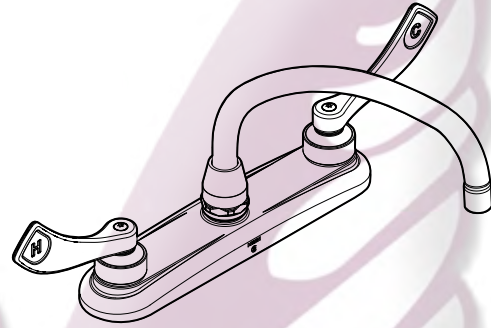

Two-Handle Kitchen Faucet

Model: 8282



NOTE: Designed to be installed through 2 or 3 holes - 1" min. dia. and on 8" on center

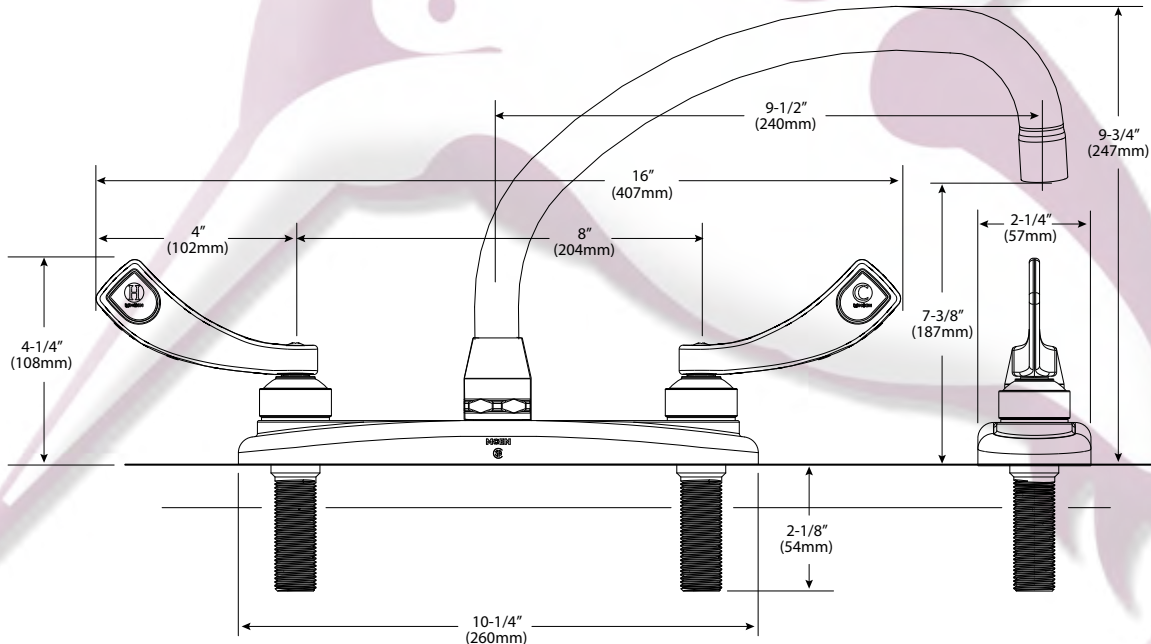

CRITICAL DIMENSIONS

(DO NOT SCALE)



Tels. (81) 8375.0992-93 con 6 líneas

www.colibrimty.com info@colibrimty.com    @colibrimty