

DESCRIPTION

- Brass construction
- Pressure balancing, four port valve design with volume control and integral check stops, 1/2" CC or IPS connections

OPERATION

- Adjustable temperature limit stop to control maximum hot water temperature
- Pressure balancing mechanism maintain selected discharge temperature to $\pm 2^\circ\text{F}$

CARTRIDGE

- 1225 cartridge design
- Nonmetallic/nonferrous and stainless steel materials
- Accommodates back to back installations

STANDARDS

- Third party certified by CSA to meet CSA B-125, ASME A112.18.1M and all applicable requirements referenced therein and complies with the applicable requirements of ANSI A117.1

WARRANTY

- Lifetime limited warranty against leaks, drips and finish defects to the original consumer purchaser
- 5 year warranty if used in commercial installations

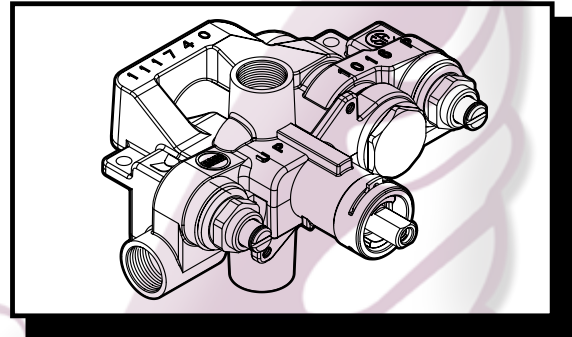

MOENTROL® VALVE
Pressure-Balancing Valve with
Volume Control

Models: 3570 (CC), 3550 (IPS) - Single Pack
63170 (CC), 63150 (IPS) - Bulk Packed
(Bulk packed 12 per carton)

NOTE: See reverse side
for illustrated parts

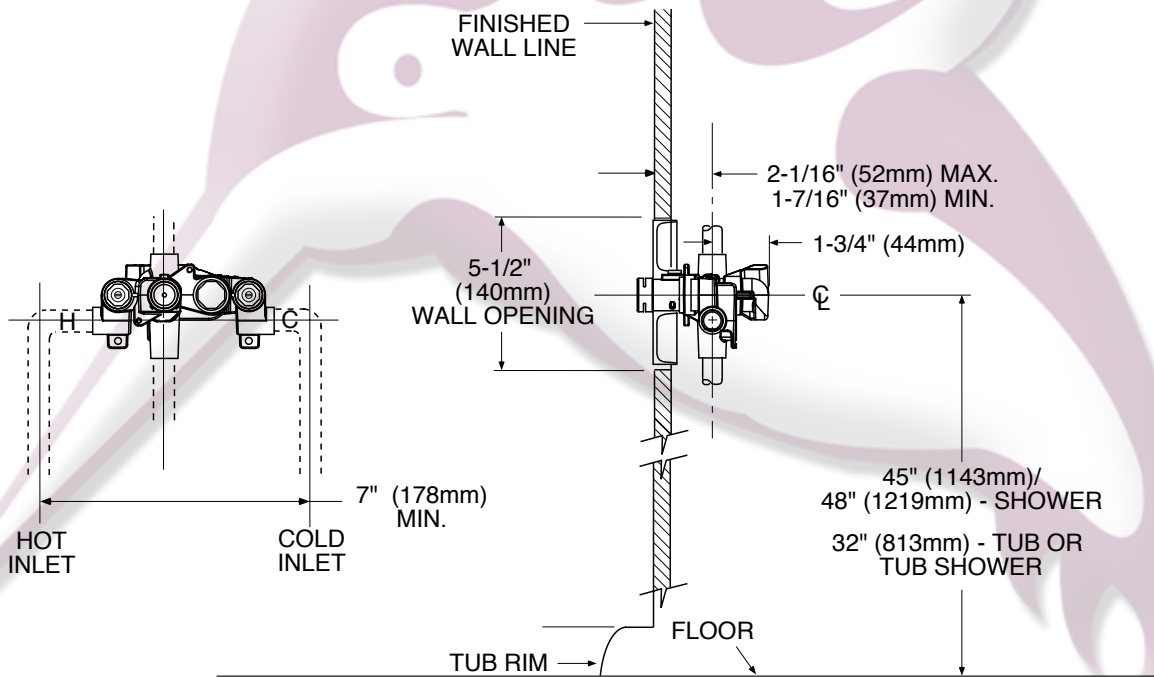

CRITICAL DIMENSIONS

(DO NOT SCALE)

